

# Product Catalog: /CZTE60

## BATTERY

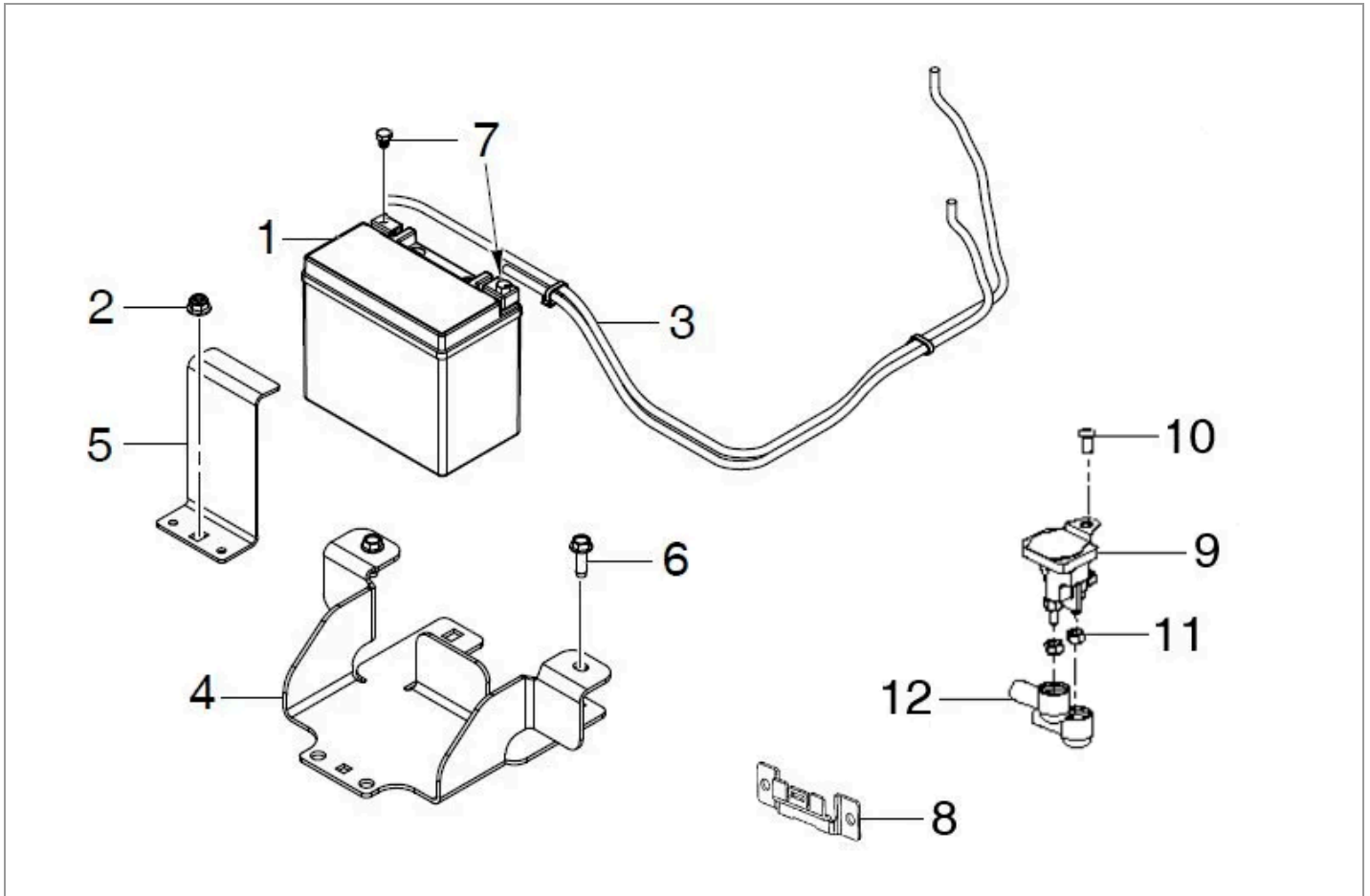

Ref.	Article N.	Description	Qty	Kit
1	589819502	BATTERY	1	-
2	594944401	NUT	1	-
3	590632102	CABLE	1	-
4	595313602	BRACKET	1	-
5	595313504	BRACKET	1	-
6	596433801	SCREW	2	-
7	582460802	SCREW	2	-
8	589500702	BRACKET	1	-
9	582042802	SOLENOID	1	-
10	539111229	SCREW	1	-
11	539976978	NUT	2	-
12	532154336	COVER	3	-

# BRAKE

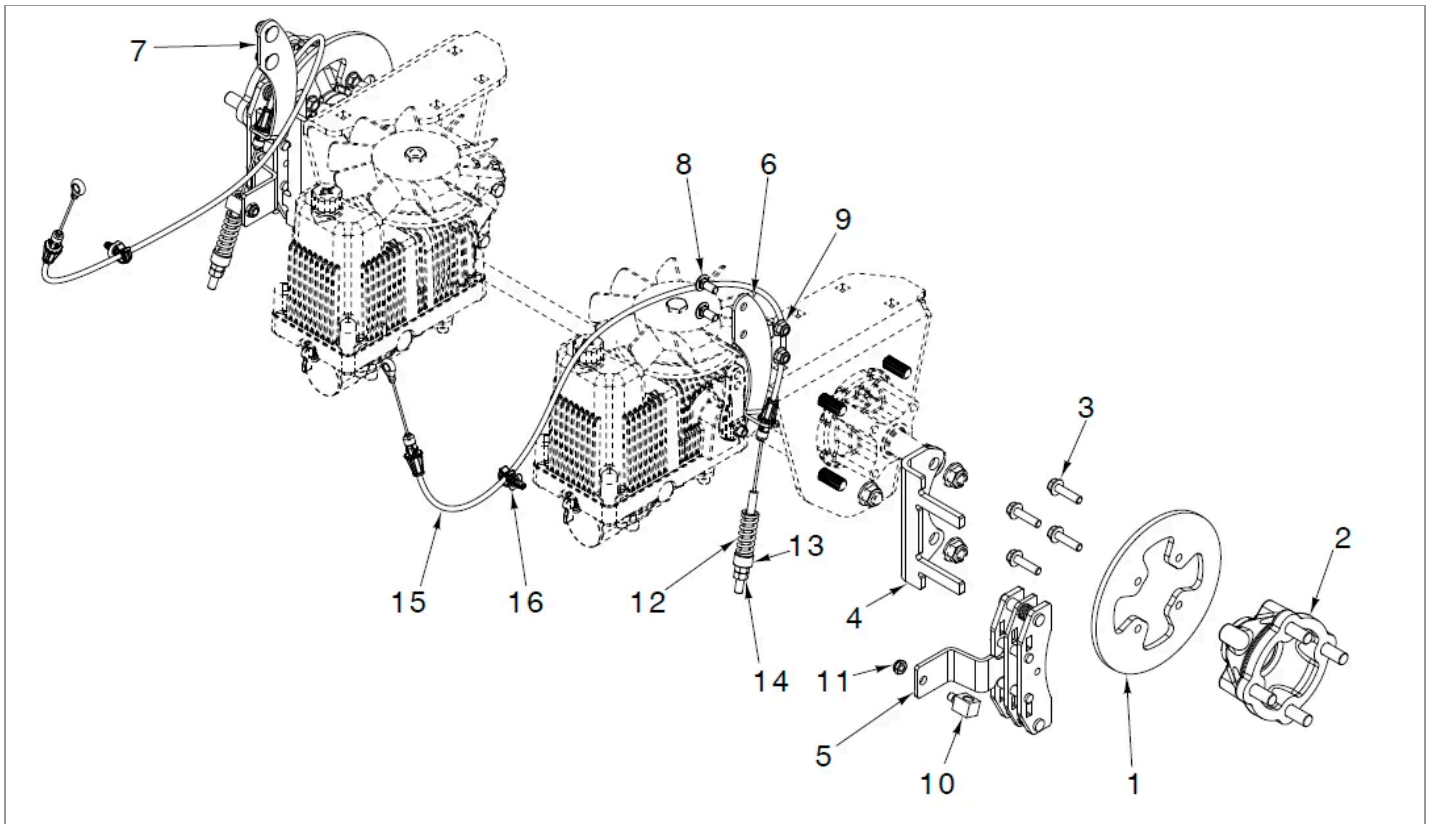

Ref.	Article N.	Description	Qty	Kit
1	597537201	ROTOR ROTOR BRAKE	2	-
2	595967702	HUB HUB CASTING W/ STUDS	1	-
3	525544002	BOLT BOLT 5/16-18UNC X 1,25 " Grade 5	1	-
4	597537001	BRACKET BRACKET MTG, CALIPER HTE10	2	-
5	597536901	CALIPER CALIPER BRAKE, PARK	2	-
6	597537101	BRACKET BRACKET, CABLE, BRAKE LH	1	-
7	597537102	BRACKET BRACKET, CABLE, BRAKE RH	1	-
8	595901601	BOLT BOLT 5/16-18UNC X 0,75 " Grade 5	1	-
9	594944401	NUT NUT HEXAGON FLANGE 5/16-18	1	-
10	525851402	SWIVEL SWIVEL BRAKE CLEAR ZINC	2	-
11	596433601	NUT NUT 5/16-18 INSERT 5/16-18 X 1/4	1	-
12	597826901	SPRING SPRING 2.00L X .50ID: 150LB_IN	1	-

<b>Ref.</b>	<b>Article N.</b>	<b>Description</b>	<b>Qty</b>	<b>Kit</b>
13	539923515	SPACER <i>SPACER</i>	1	-
14	596040901	HEXAGON NUT <i>HEX NUT 5/16-24 IN GRF</i>	1	-
15	597773501	CABLE <i>CABLE BRAKE, PARKING DISC</i>	2	-
16	592857401	CLIP <i>CLIP CABLE, 1/4 BLACK FIR TREE</i>	1	-

# CLUTCH

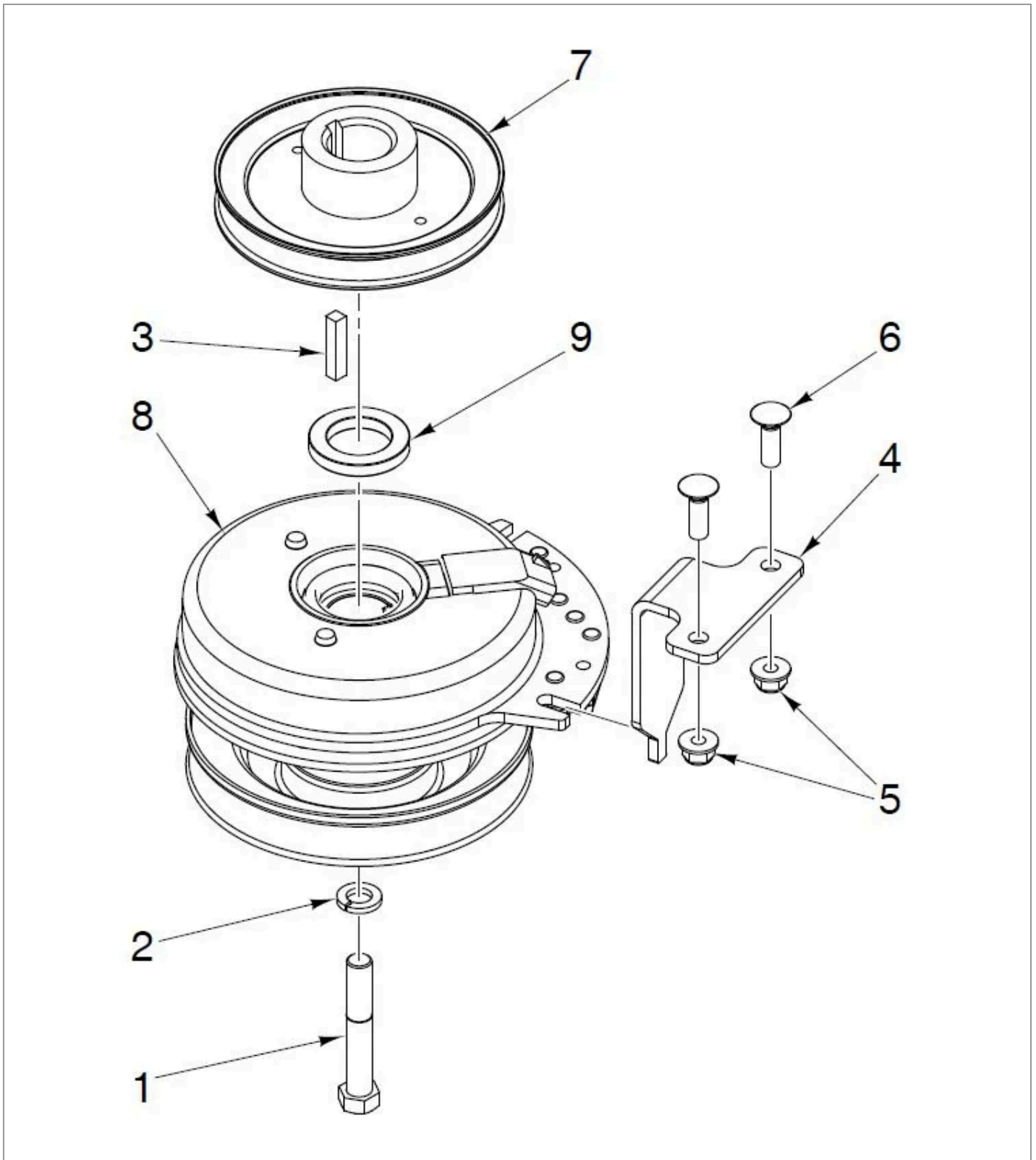

Ref.	Article N.	Description	Qty	Kit
1	581332807	BOLT	1	-
2	596238901	WASHER	1	-

<b>Ref.</b>	<b>Article N.</b>	<b>Description</b>	<b>Qty</b>	<b>Kit</b>
3	539912757	KEY	1	-
4	594082301	BRACKET	1	-
5	594944401	NUT	2	-
6	595901501	BOLT	2	-
7	574811001	PULLEY	1	-
8	574607001	CLUTCH	1	-
9	525313902	SPACER	1	-

# CONTROL PANEL

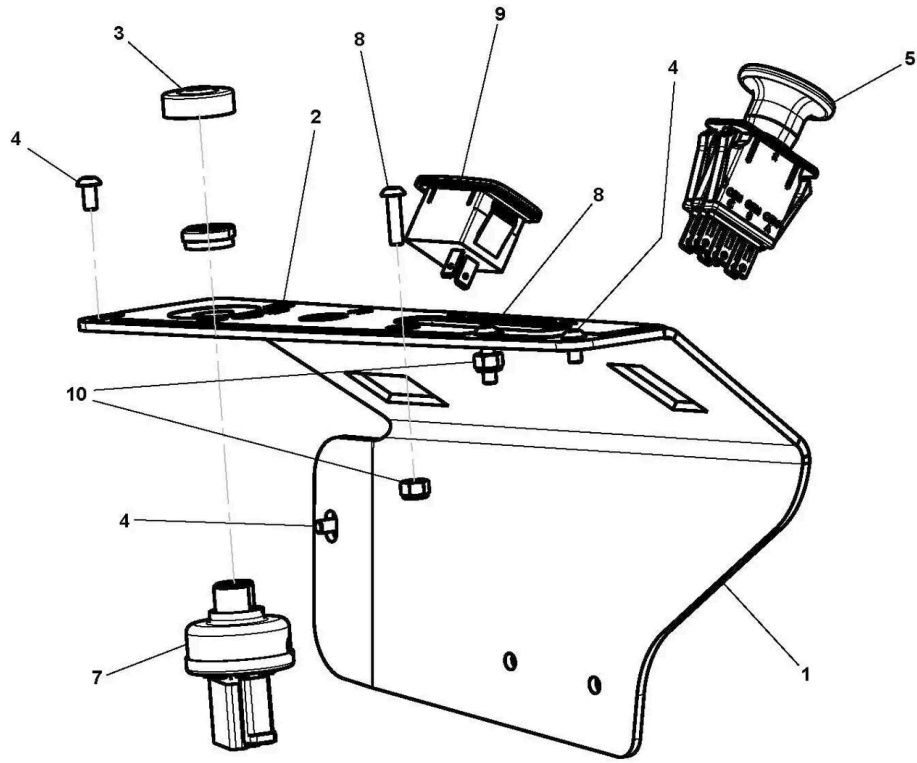

Ref.	Article N.	Description	Qty	Kit
1	592979103	PANEL	1	-
2	590801102	DECAL	1	-

Ref.	Article N.	Description	Qty	Kit
3	539103178	NUT CAP	1	-
4	539114341	SCREW	3	-
5	589887201	SWITCH	1	-
7	574455401	SWITCH	1	-
8	574822701	SCREW	2	-
9	539132624	KNOB <i>THROTTLE</i>	1	-
9	594919101	HOUR METER	1	-
10	596040801	LOCK NUT	2	-
10	574207001	CABLE <i>THROTTLE</i>	1	-
11	574206905	CABLE <i>CHOKE</i>	1	-
12	595840604	HARNESS <i>MAIN</i>	1	-
13	595840702	HARNESS <i>TANK</i>	1	-
14	597759301	HARNESS <i>PARK BRAKE</i>	1	-
15	597860401	HARNESS <i>STARTER</i>	1	-
16	582042802	SOLENOID <i>NOT SHOWN (SOLENOID KAW FS/FX)</i>	1	-

# CROSS MEMBER & FAN COVERS

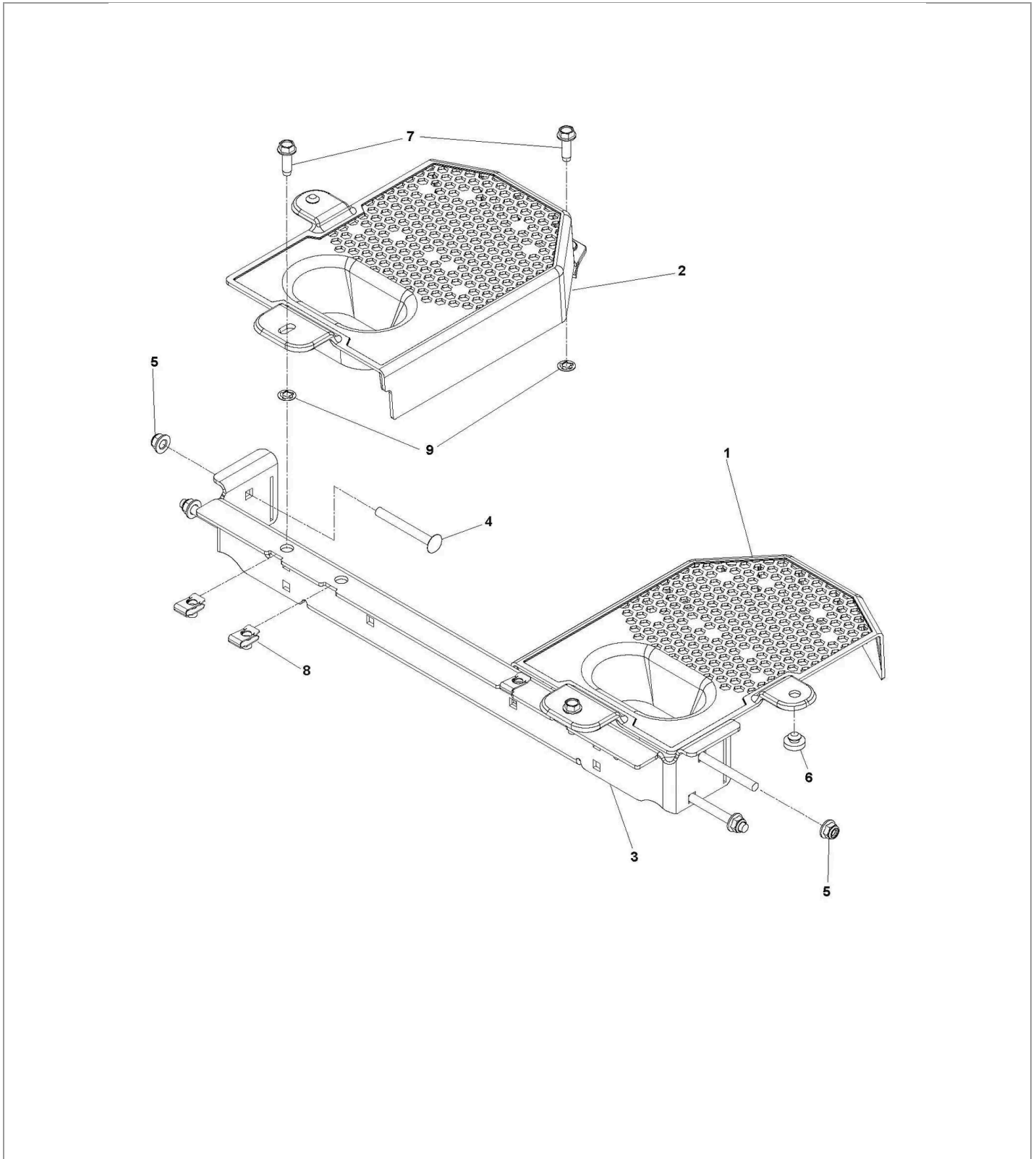

Ref.	Article N.	Description	Qty	Kit
1	598468402	MODULE KIT LH FAN SHIELD	1	-



<b>Ref.</b>	<b>Article N.</b>	<b>Description</b>	<b>Qty</b>	<b>Kit</b>
2	598468401	MODULE <i>KIT RH FAN SHIELD</i>	1	-
3	596972703	BRACKET	1	-
4	874490548	BOLT	4	-
5	594944401	NUT	4	-
6	539102587	ABSORBER	2	-
7	596433801	SCREW	4	-
8	539104763	CLIP	4	-
9	532423063	WASHER	4	-

# DECALS

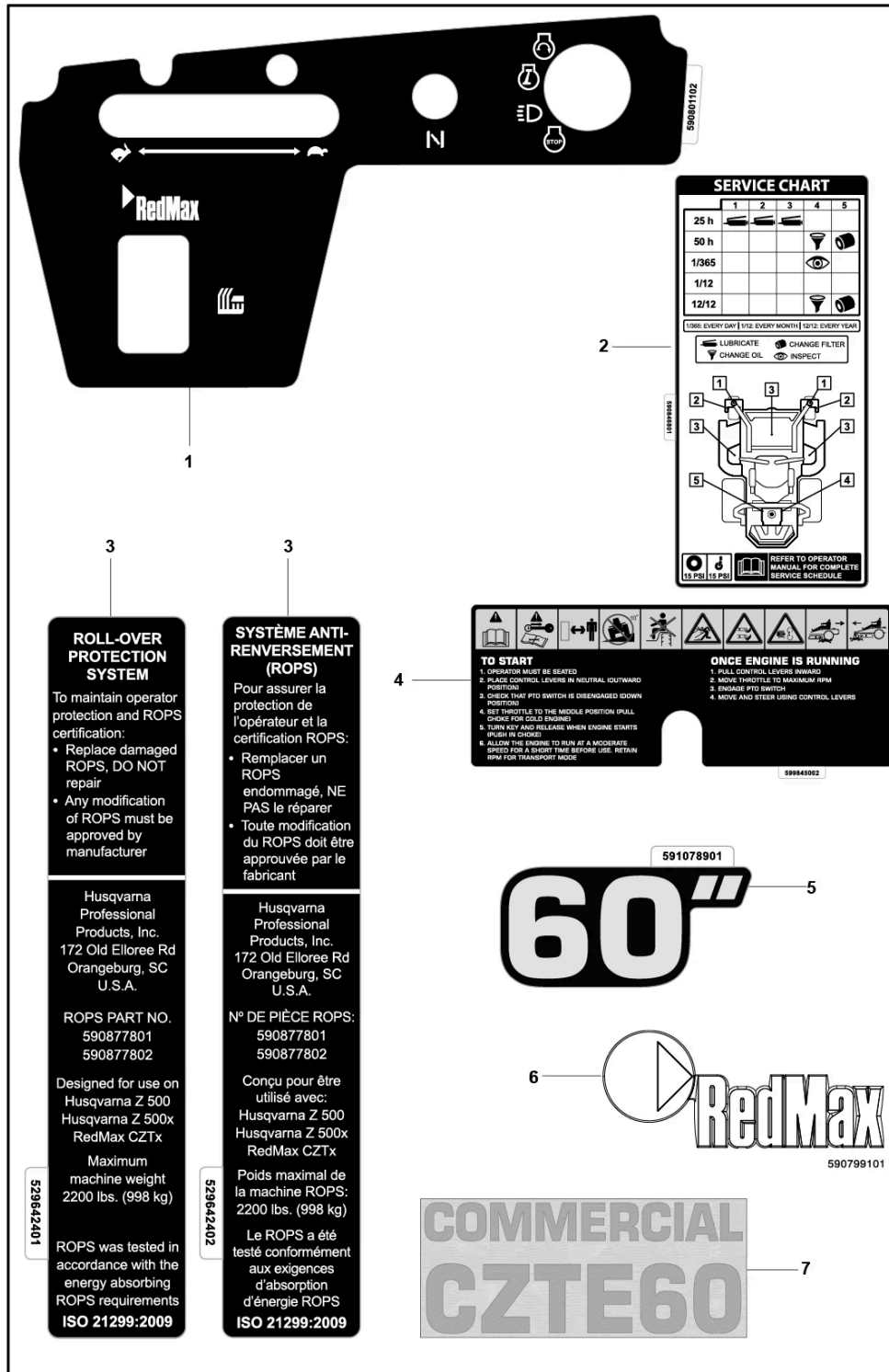

Ref.	Article N.	Description	Qty	Kit
1	590801102	DECAL	1	-
2	590846801	DECAL	1	-

<b>Ref.</b>	<b>Article N.</b>	<b>Description</b>	<b>Qty</b>	<b>Kit</b>
3	529642401	DECAL	1	-
3	529642402	DECAL <i>French</i>	1	-
4	599845002	DECAL	1	-
5	591078901	DECAL	1	-
6	591078901	DECAL	1	-
7	531197301	DECAL	1	-

# DECALS

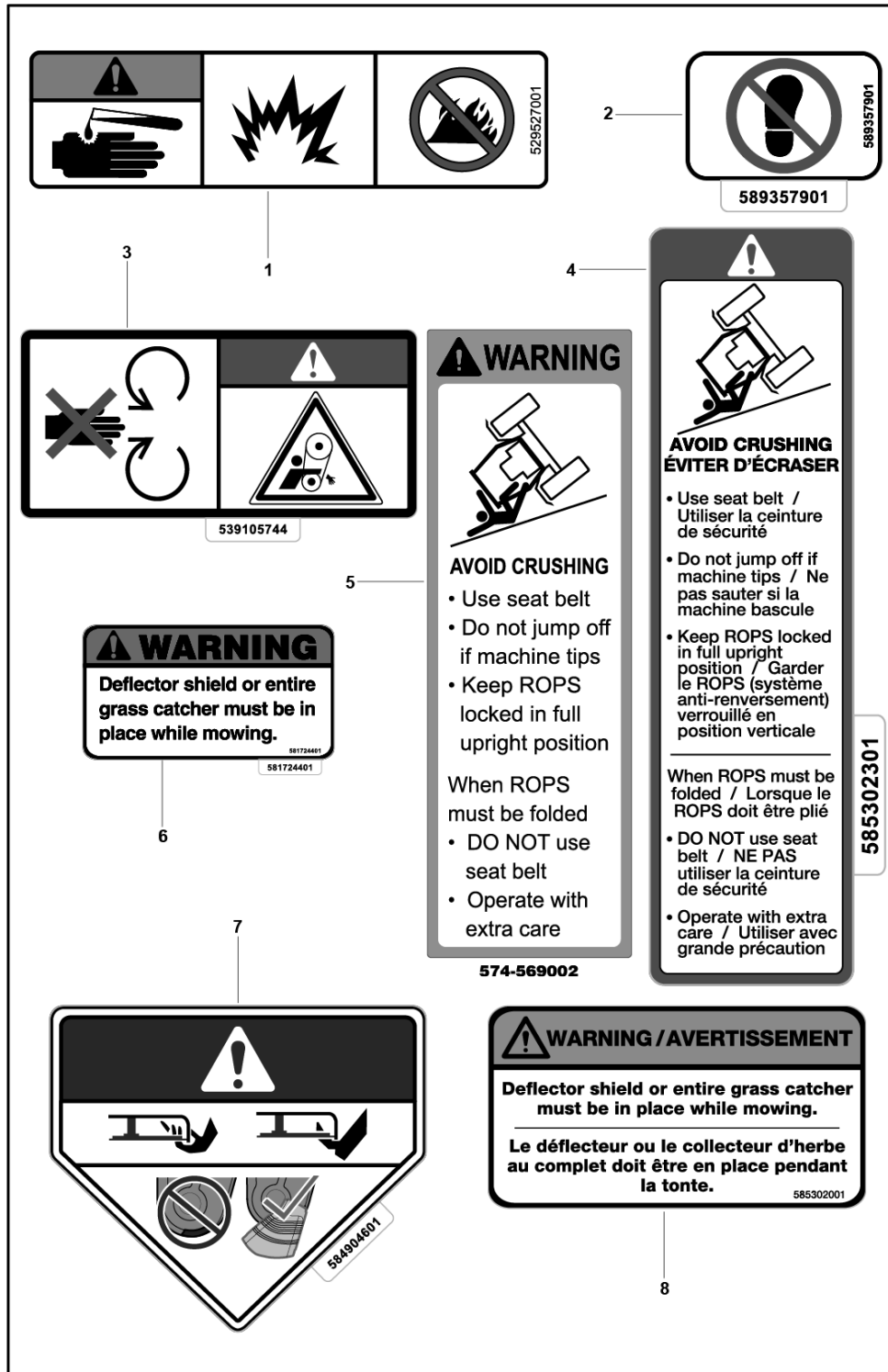

Ref.	Article N.	Description	Qty	Kit
1	529527001	DECAL	1	-
2	589357901	DECAL	2	-

<b>Ref.</b>	<b>Article N.</b>	<b>Description</b>	<b>Qty</b>	<b>Kit</b>
3	539105744	DECAL	2	-
4	585302301	DECAL	1	-
5	574569002	DECAL	1	-
6	581724401	DECAL	1	-
7	584904601	DECAL	1	-
8	585302001	DECAL	1	-

# DECALS

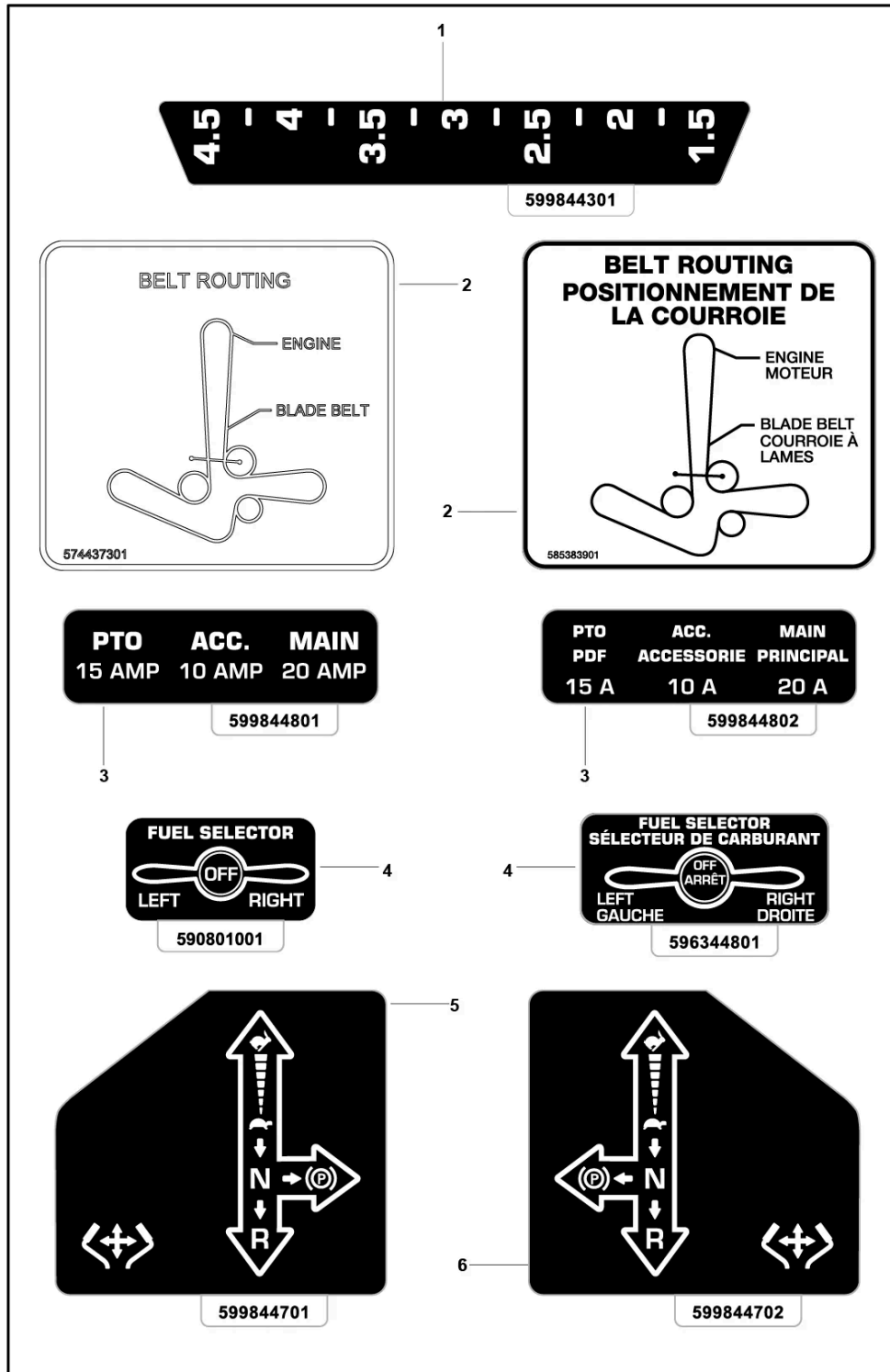

Ref.	Article N.	Description	Qty	Kit
1	599844301	DECAL	1	-
2	574437301	DECAL	1	-

<b>Ref.</b>	<b>Article N.</b>	<b>Description</b>	<b>Qty</b>	<b>Kit</b>
2	585383901	DECAL	1	-
3	599844802	DECAL	1	-
3	599844801	DECAL	1	-
4	590801001	DECAL	1	-
4	596344801	DECAL	1	-
5	599844701	DECAL	1	-
6	599844702	DECAL	1	-

# DRIVE

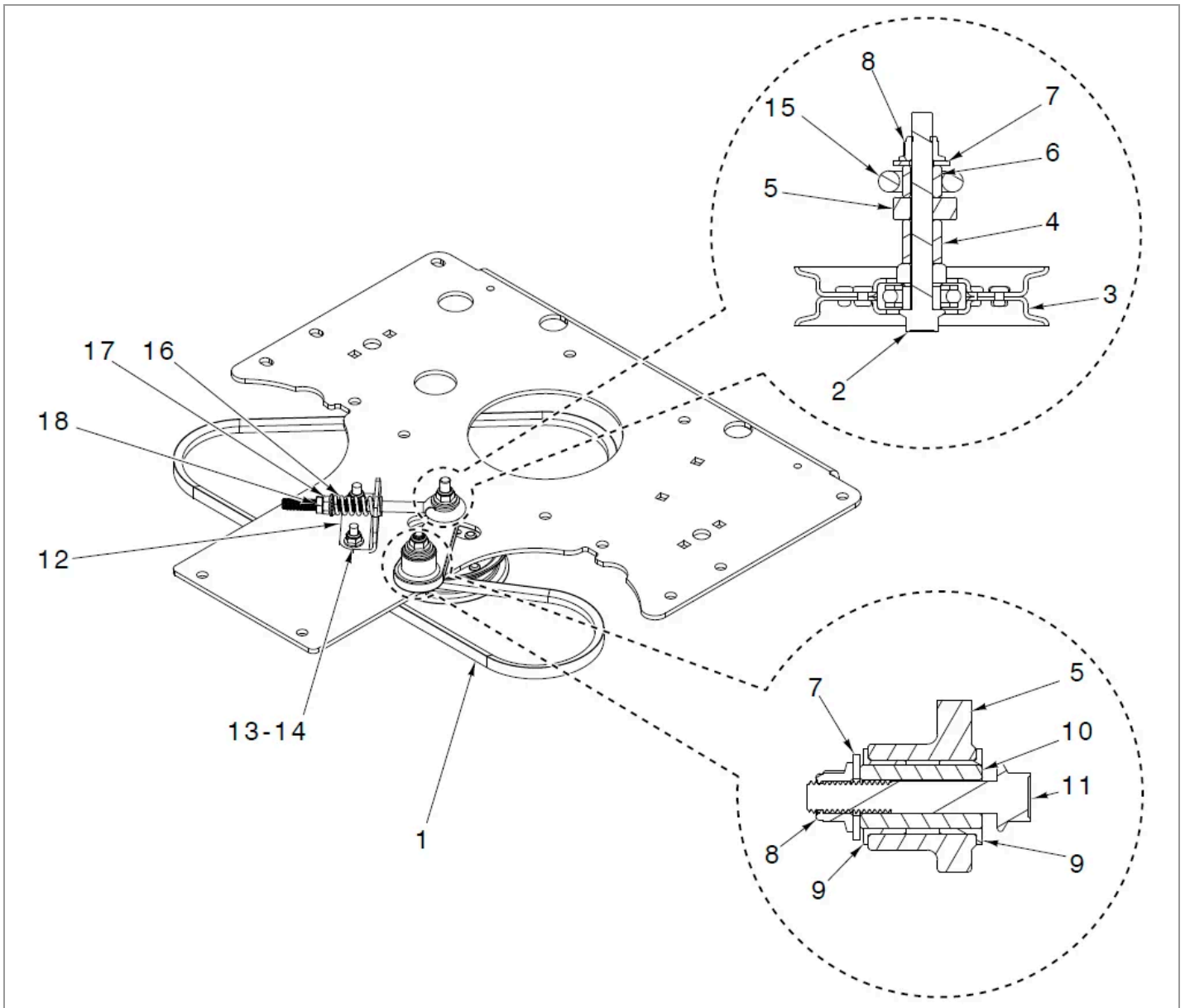

Ref.	Article N.	Description	Qty	Kit
1	594098801	DRIVE BELT <i>BELT GROUND DRIVE, HA 60.75</i>	1	-
2	525822101	BOLT <i>BOLT 3/8-16 X 3.5 HHFS GD 5</i>	1	-
3	596481401	PULLEY <i>PULLEY PULLEY.IDLER.FLAT.3.</i>	1	-
4	594099902	SPACER <i>SPACER HG .781</i>	1	-
5	594099101	ARM <i>ARM IDLER Z400_300</i>	1	-
6	594099901	SPACER <i>SPACER PRKR .557</i>	1	-
7	596433701	WASHER <i>WASHER 3/8 FLAT STD ZD 0.453 X 1.030 X 0.104 IN ST</i>	1	-



Ref.	Article N.	Description	Qty	Kit
8	521996502	NUT <i>NUT HEX LOCK FLANGE 3/8-16 St</i>	4	-
9	501603701	BEARING <i>BEARING FLANGED 3/4ID X 1/2L</i>	2	-
10	594100201	SPACER <i>SPACER PIVOT, TENSION ARM</i>	1	-
11	577098301	BOLT <i>HHFS 3/8-16 X 2.25 GD 8</i>	1	-
12	594100301	BRACKET <i>BRACKET ANCHOR, TENSIONER</i>	1	-
13	595901501	BOLT <i>BOLT CUP HEAD 5/16-18 x 1.02 IN</i>	1	-
14	594944401	NUT <i>NUT HEX FLANGE 5/16-18 St ZPB</i>	1	-
15	594100401	LINKAGE <i>LINKAGE TENSIONER</i>	1	-
16	532151332	SPRING <i>SPRING</i>	1	-
17	596583501	WASHER <i>WASHER HEX LOCK NUT WITH FLANGE 3/8-16 X 0.765 IN ST</i>	1	-
18	596433501	NUT <i>NUT 3/8-16 HEX JAM 3/8-16 X .562 IN</i>	1	-

# ENGINE PLATE

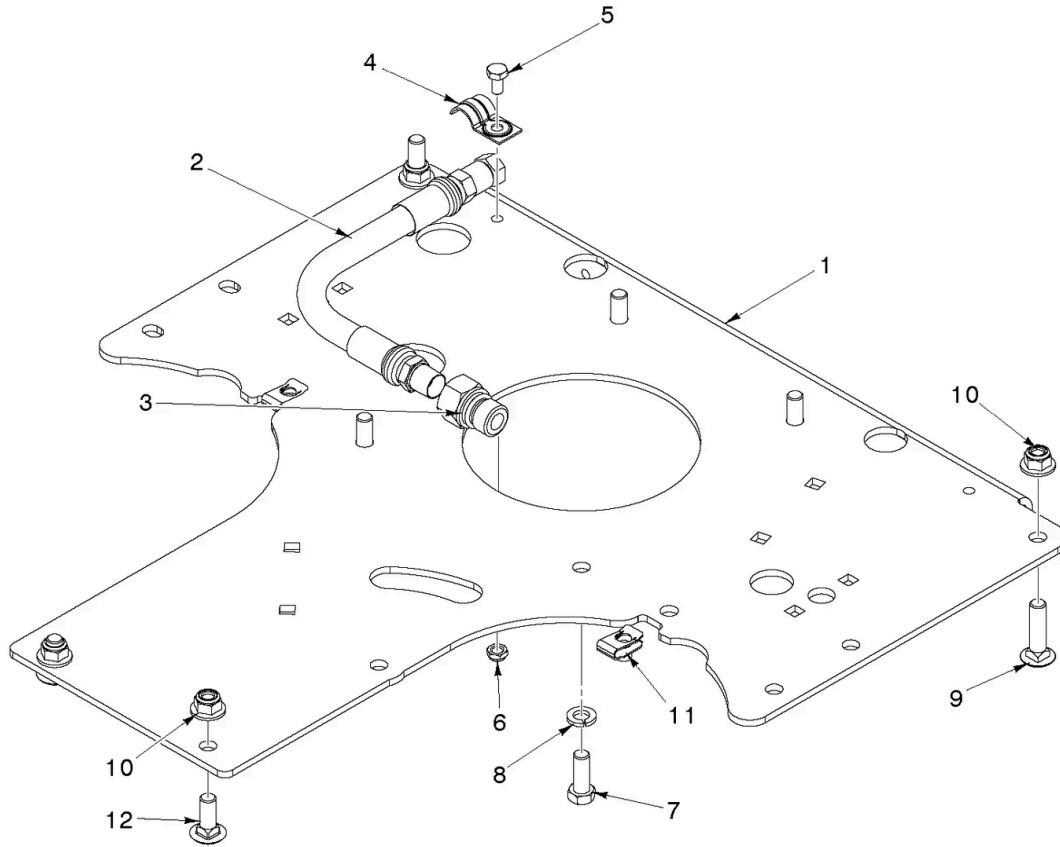

Ref.	Article N.	Description	Qty	Kit
1	598496301	MODULE <i>Engine Plate Kit, w/ clips &amp; decal</i>	1	-
2	584825501	HOSE ASSY	1	-

<b>Ref.</b>	<b>Article N.</b>	<b>Description</b>	<b>Qty</b>	<b>Kit</b>
3	522599002	ADAPTER	1	-
4	539101363	CLAMP	1	-
5	596437001	SCREW	1	-
6	596031501	LOCK NUT	1	-
7	596564401	BOLT	4	-
8	596238701	WASHER	4	-
9	596136101	BOLT	2	-
10	521996502	NUT	4	-
11	539104763	CLIP	2	-
12	595316801	BOLT	2	-

# FRAME - CHASSIS

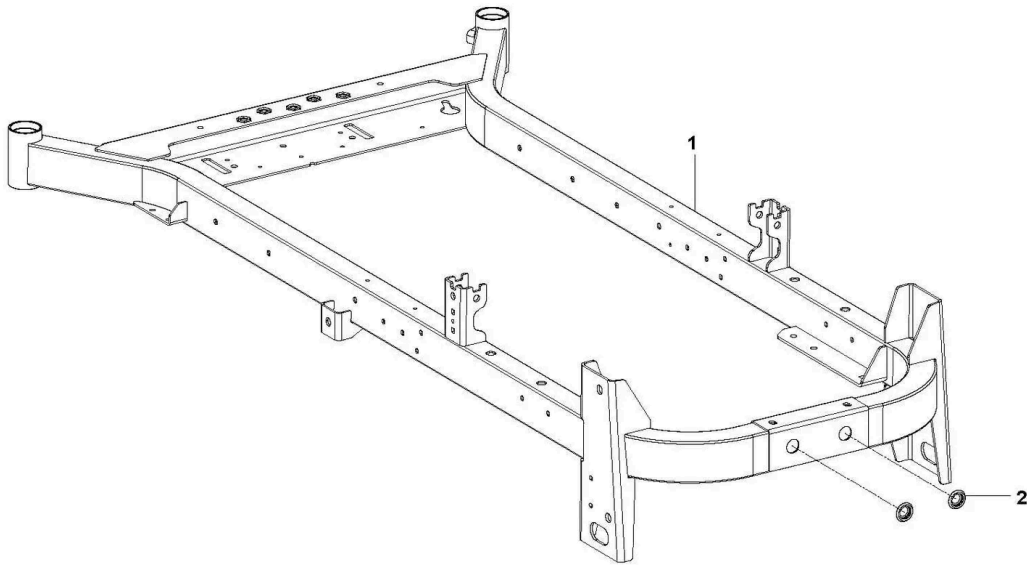

Ref.	Article N.	Description	Qty	Kit
1	501656007	FRAME	1	-
2	587990501	CAP	2	-

# FRAME - FOOT PLATE

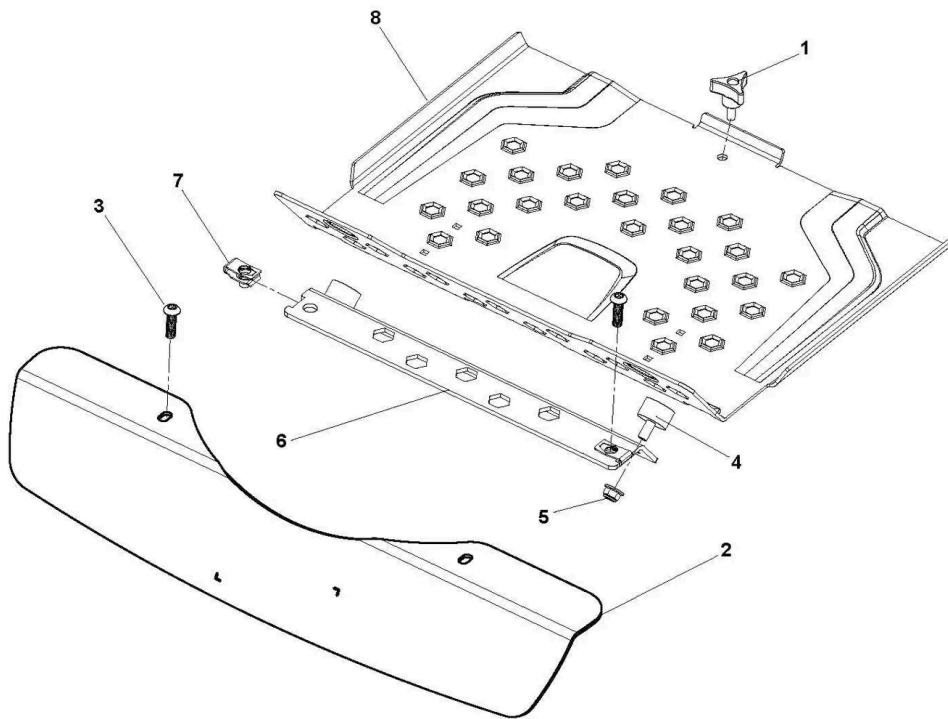

Ref.	Article N.	Description	Qty	Kit
1	597783101	KNOB	1	-
2	599868702	COVER	1	-

<b>Ref.</b>	<b>Article N.</b>	<b>Description</b>	<b>Qty</b>	<b>Kit</b>
3	589797202	SCREW	2	-
4	589744002	ISOLATOR	2	-
5	521996502	NUT	2	-
6	595528902	BRACKET	1	-
7	589806801	NUT	2	-
8	589304603	PLATE	1	-

# FRAME - REAR GUARDS

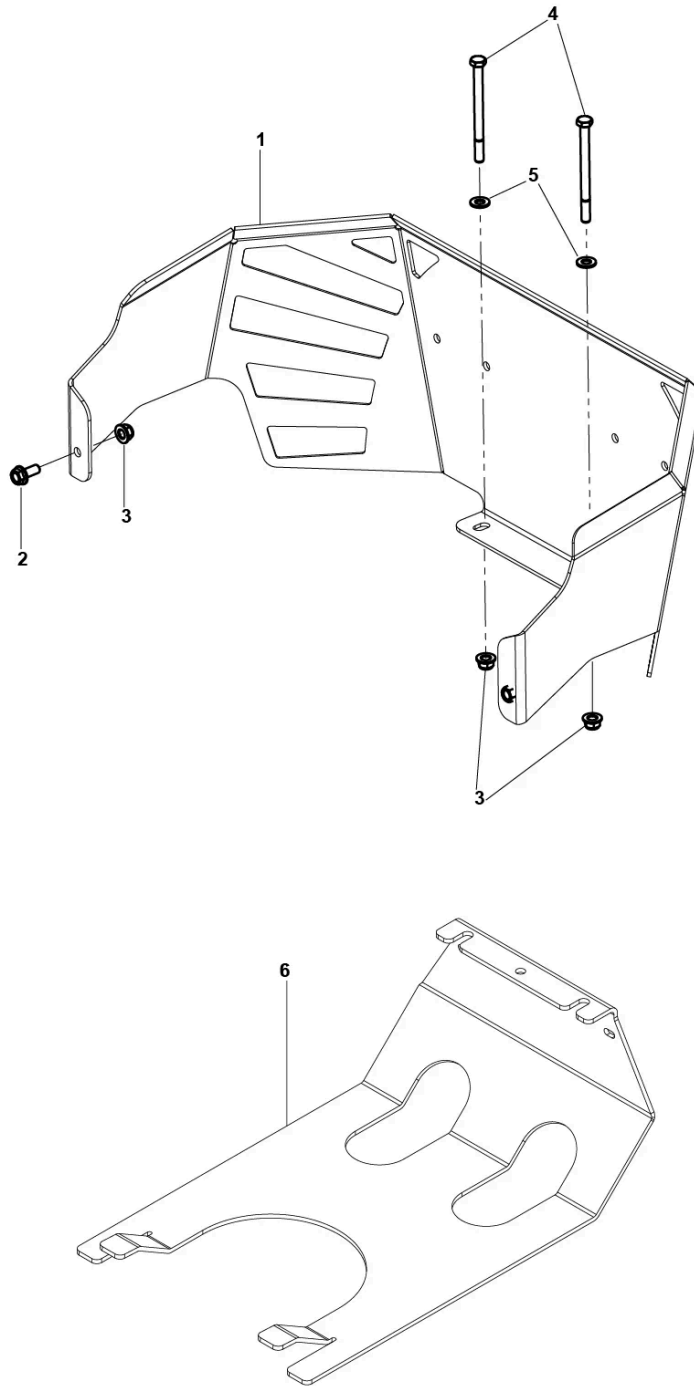

Ref.	Article N.	Description	Qty	Kit
1	576878604	GUARD	1	-
2	592858702	BOLT	2	-

<b>Ref.</b>	<b>Article N.</b>	<b>Description</b>	<b>Qty</b>	<b>Kit</b>
3	594944401	NUT	4	-
4	596435501	BOLT	2	-
5	596204101	WASHER	2	-
6	593795504	GUARD	1	-



# FRAME - ROLL PROTECTION

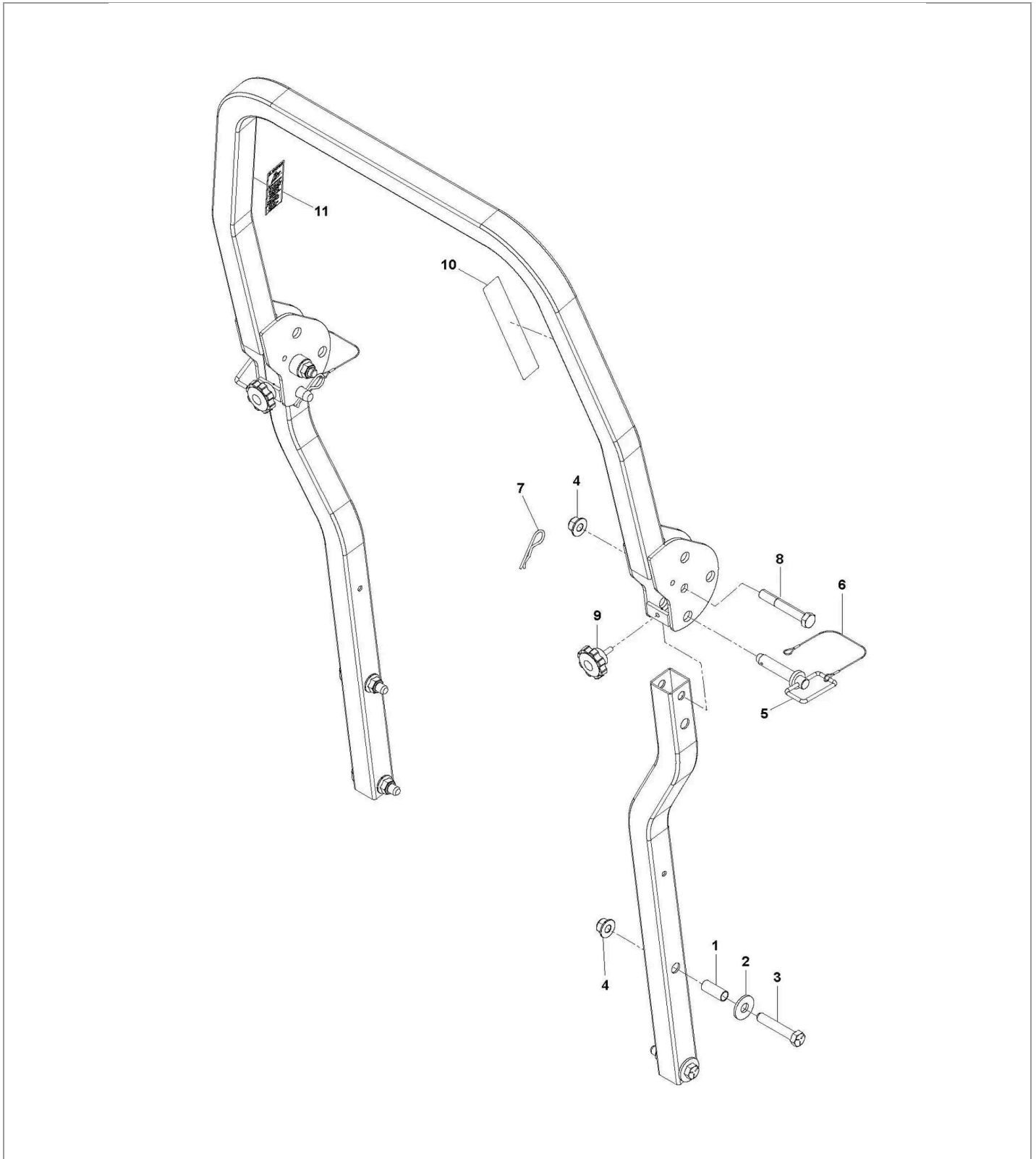

Ref.	Article N.	Description	Qty	Kit
0	598429106	ROPS COMPLETE	1	-
2	594946401	WASHER	1	-

<b>Ref.</b>	<b>Article N.</b>	<b>Description</b>	<b>Qty</b>	<b>Kit</b>
3	580754602	BOLT	1	-
4	525829102	NUT	1	-
5	591101602	PIN	1	-
6	591101702	PIN	1	-
7	596918001	PIN	1	-
8	591176602	BOLT	1	-
9	591344501	KNOB	1	-
10	529502701	DECAL	1	-
11	574569002	DECAL	1	-

# FRAME - SEAT DECK

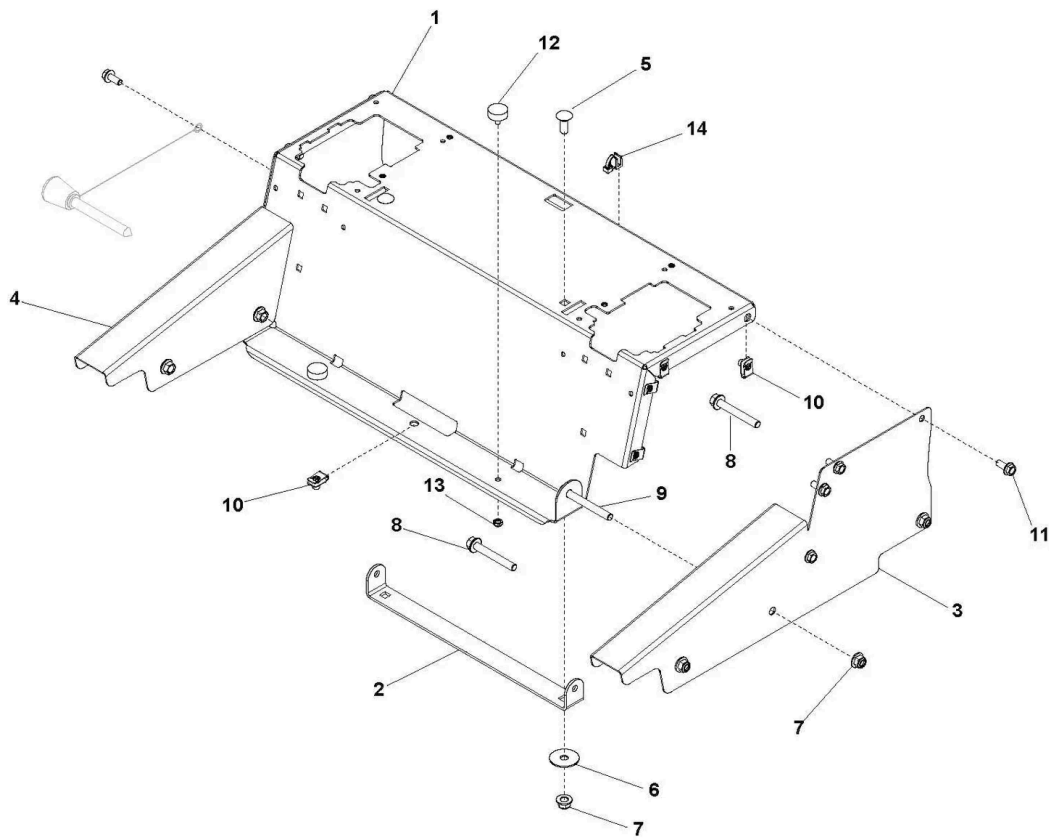

Ref.	Article N.	Description	Qty	Kit
1	595306606	SUPPORT	1	-
2	595306702	BRACKET	1	-

<b>Ref.</b>	<b>Article N.</b>	<b>Description</b>	<b>Qty</b>	<b>Kit</b>
3	595311005	PLATE	1	-
4	595311006	PLATE	1	-
5	595316801	BOLT	2	-
6	596133301	WASHER	2	-
7	521996502	NUT	9	-
8	596436901	SCREW	5	-
9	577117702	BOLT	2	-
10	539104763	CLIP	9	-
11	592858702	BOLT	8	-
12	575811501	BUMPER	2	-
13	596031501	LOCK NUT	2	-
14	595306201	ZIP TIE	2	-

# FUEL LINE & VALVE

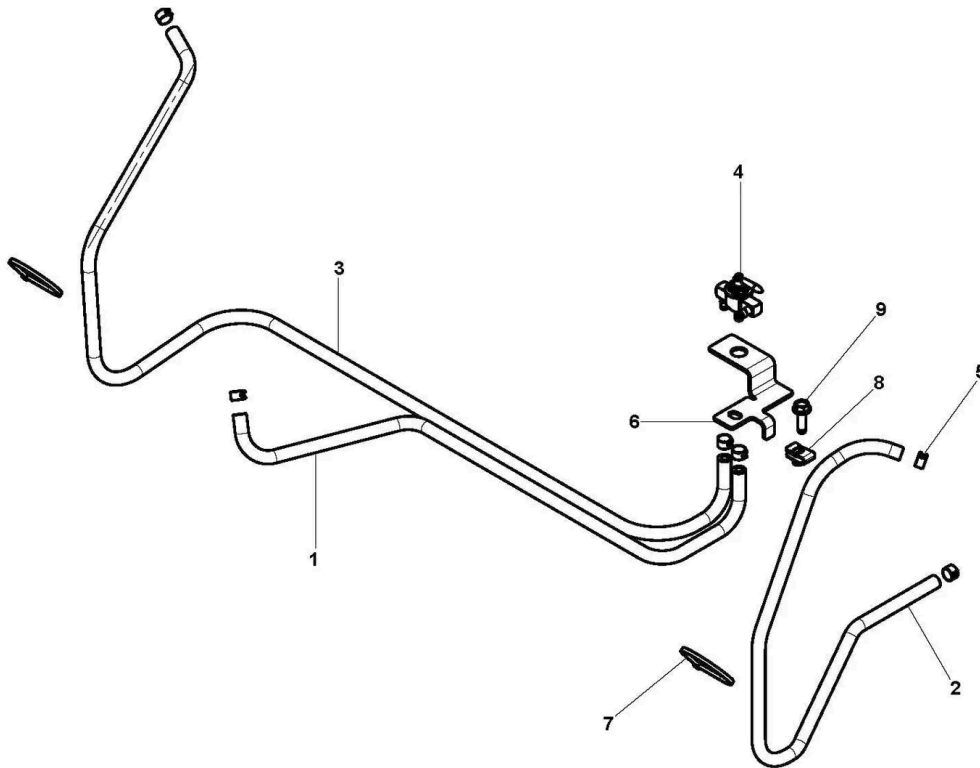
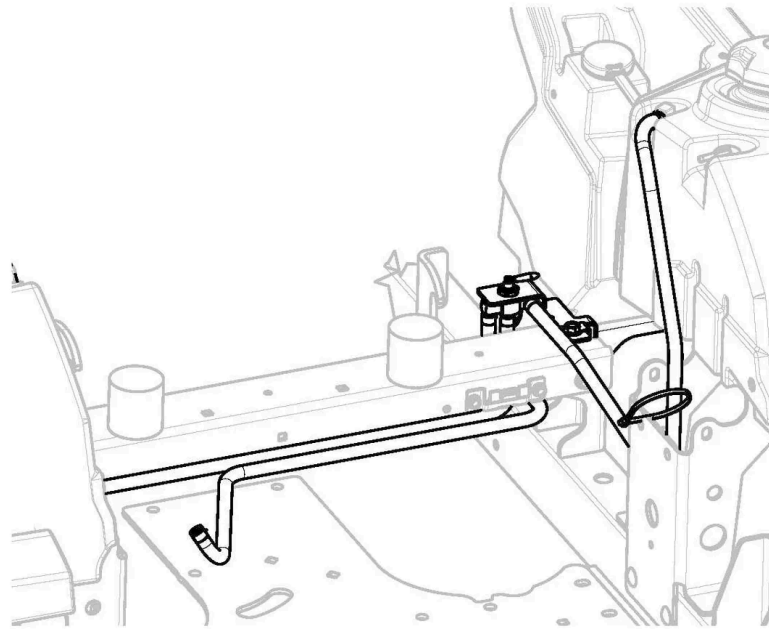

Ref.	Article N.	Description	Qty	Kit
1	587044820	HOSE CUT TO LENGTH	1	-

<b>Ref.</b>	<b>Article N.</b>	<b>Description</b>	<b>Qty</b>	<b>Kit</b>
2	587044833	HOSE <i>CUT TO LENGTH</i>	1	-
3	587044854	HOSE <i>CUT TO LENGTH</i>	1	-
4	598462501	VALVE	1	-
5	575436501	CLAMP	6	-
6	529461502	BRACKET	1	-
7	539976856	TIE WRAP	2	-
8	539104763	CLIP	1	-
9	596433801	SCREW	1	-

# FUEL SYSTEM - VAPOR LINE

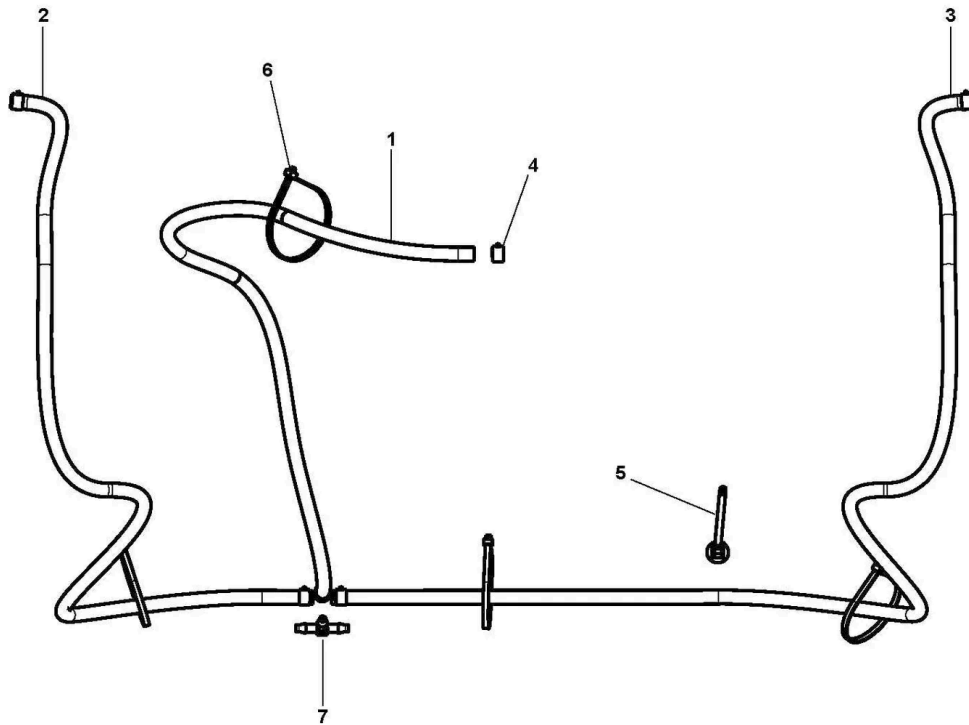
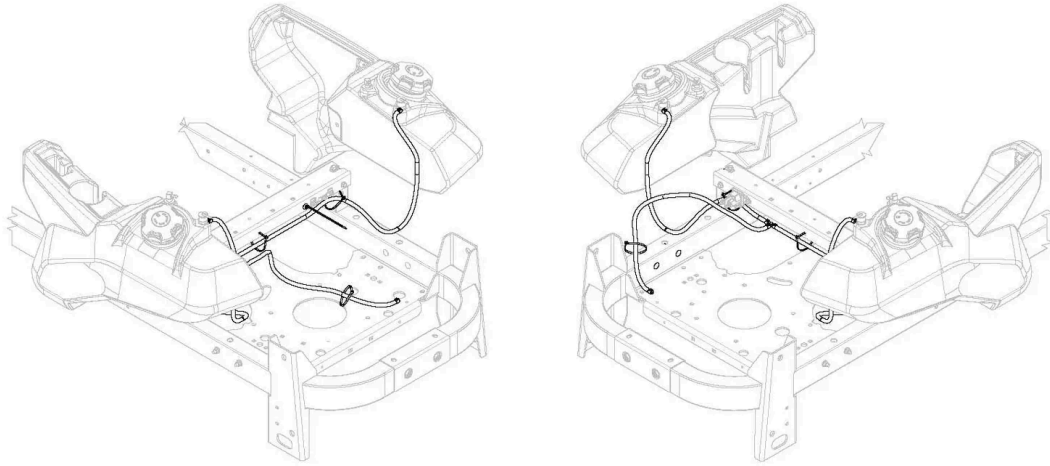

Ref.	Article N.	Description	Qty	Kit
1	587044526	HOSE <i>CUT TO LENGTH</i>	1	-
2	587044527	HOSE	1	-

<b>Ref.</b>	<b>Article N.</b>	<b>Description</b>	<b>Qty</b>	<b>Kit</b>
3	587044541	HOSE <i>CUT TO LENGTH</i>	1	-
4	575436501	CLAMP	6	-
5	591367101	CABLE	1	-
6	539976856	TIE WRAP	4	-
7	574206602	FITTING	1	-



# FUEL TANK & CONSOLE

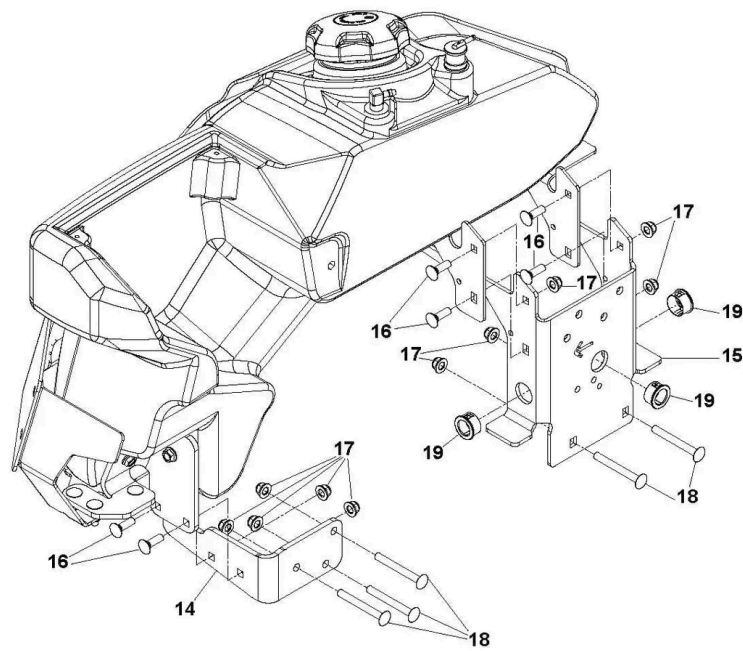
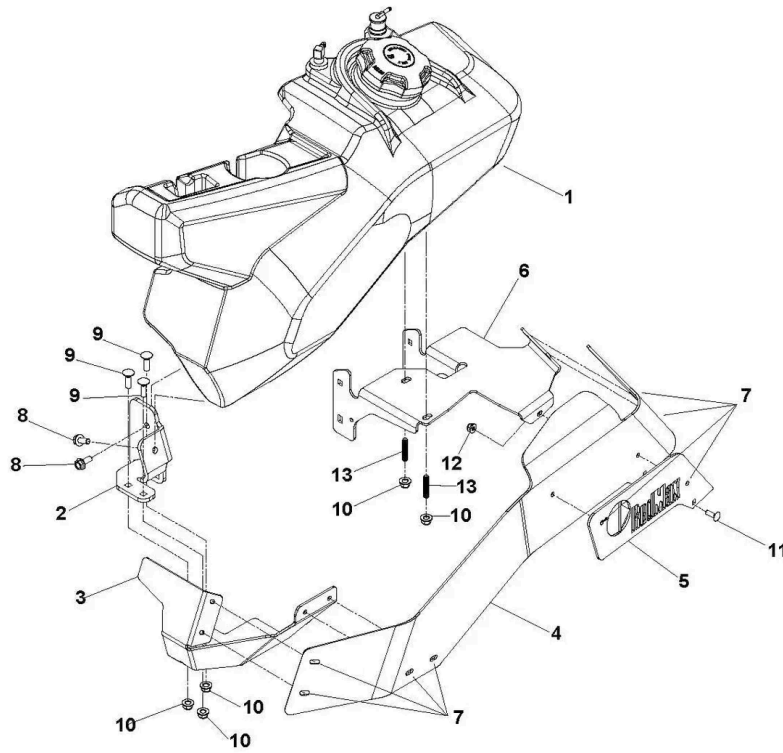

Ref.	Article N.	Description	Qty	Kit
1	589997304	FUEL TANK ASSY LH	1	-

Ref.	Article N.	Description	Qty	Kit
1	590026004	FUEL TANK ASSY <i>RH</i>	1	-
2	529516803	BRACKET <i>LH</i>	1	-
2	529516804	BRACKET <i>RH</i>	1	-
3	529516904	GUARD <i>RH</i>	1	-
3	529516903	GUARD <i>LH</i>	1	-
4	529517103	GUARD <i>LH</i>	1	-
4	529517104	GUARD <i>RH</i>	1	-
5	529517204	GUARD <i>RH</i>	1	-
5	529517203	GUARD <i>LH</i>	1	-
6	529517304	GUARD <i>RH</i>	1	-
6	529517303	GUARD <i>LH</i>	1	-
7	588119401	RIVET	16	-
8	592858701	BOLT	4	-
9	595901501	BOLT	6	-
10	594944401	NUT	10	-
11	596238401	BOLT	4	-
12	582478602	NUT	4	-
13	582484201	SCREW	4	-
14	529516603	BRACKET <i>LH</i>	1	-
14	529516604	BRACKET <i>RH</i>	1	-
15	529517603	BRACKET <i>LH</i>	1	-
15	529517604	BRACKET <i>RH</i>	1	-
16	595901501	BOLT	12	-
17	594944401	NUT	22	-
18	872110522	BOLT	10	-
19	596773901	BUSHING	6	-

# FUEL TANK PARTS

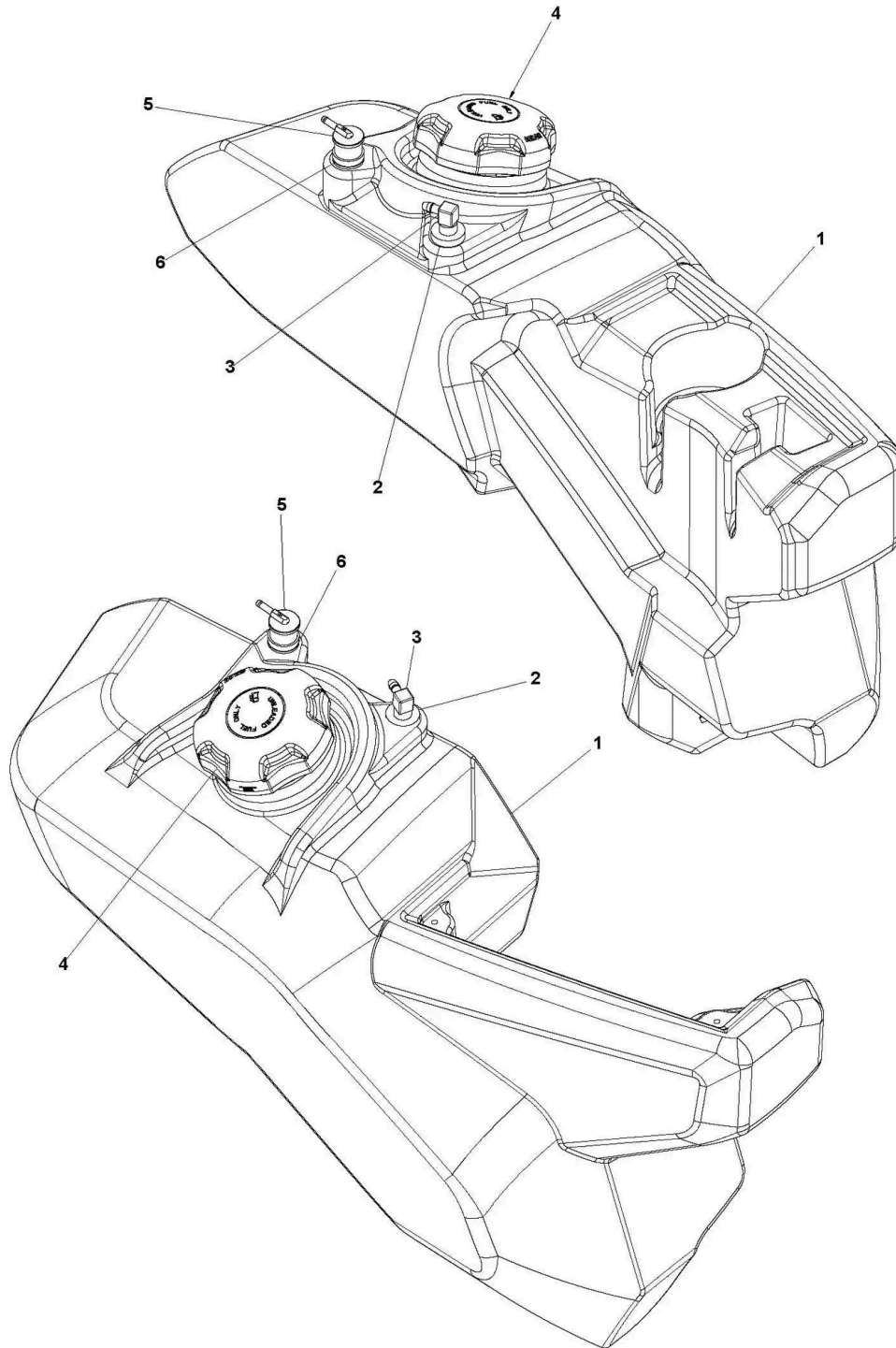

Ref.	Article N.	Description	Qty	Kit
1	589997304	FUEL TANK ASSY LH	1	-

<b>Ref.</b>	<b>Article N.</b>	<b>Description</b>	<b>Qty</b>	<b>Kit</b>
1	590026004	FUEL TANK ASSY <i>RH</i>	1	-
2	539105245	GROMMET	2	-
3	525865401	TUBE ASSY	2	-
4	575018103	CAP	2	-
5	576618101	TANK VENT	2	-
6	584648201	GROMMET	2	-

# MOWER LIFT / DECK LIFT

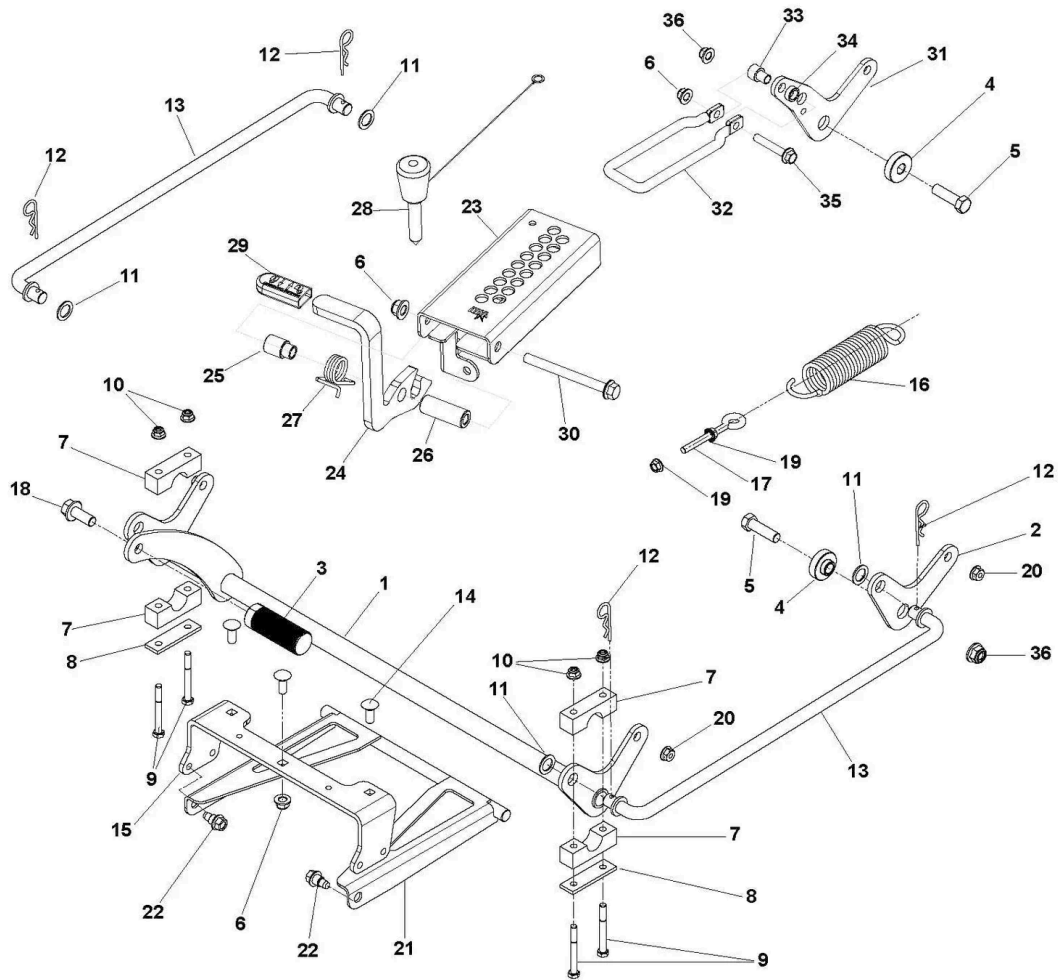

Ref.	Article N.	Description	Qty	Kit
1	592809002	SHAFT	1	-
2	593077704	ARM	1	-

<b>Ref.</b>	<b>Article N.</b>	<b>Description</b>	<b>Qty</b>	<b>Kit</b>
3	510408302	PEDAL	1	-
4	586701702	SPACER	2	-
5	596435801	BOLT	2	-
6	521996502	NUT	3	-
7	539104808	SUPPORT	4	-
8	584392702	PLATE	2	-
9	596218601	BOLT	4	-
10	594944401	NUT	4	-
11	596933401	WASHER	4	-
12	596273101	PIN	4	-
13	591066901	ROD	1	-
14	595316801	BOLT	3	-
15	582519402	BRACKET	1	-
16	596848001	SPRING	1	-
17	596240801	BOLT	1	-
18	593903401	BOLT	1	-
19	596039201	LOCK NUT	2	-
20	873900600	NUT	4	-
21	591067402	DRAWBAR	1	-
22	532196539	BOLT	2	-
23	590934305	HEIGHT ADJUSTER	1	-
24	589454202	LEVER	1	-
25	594037301	PIVOT	1	-
26	510408402	SPACER	1	-
27	590937501	SPRING	1	-
28	592914203	PIN	1	-
29	539132851	GRIP	1	-
30	521996602	SCREW	1	-
31	593077703	ARM	1	-
32	590934701	LINK ROD	1	-
33	594037201	PIVOT	1	-
34	596515201	SPACER	1	-
35	596438301	BOLT	1	-
36	521991102	NUT	2	-

# MOWING DECK

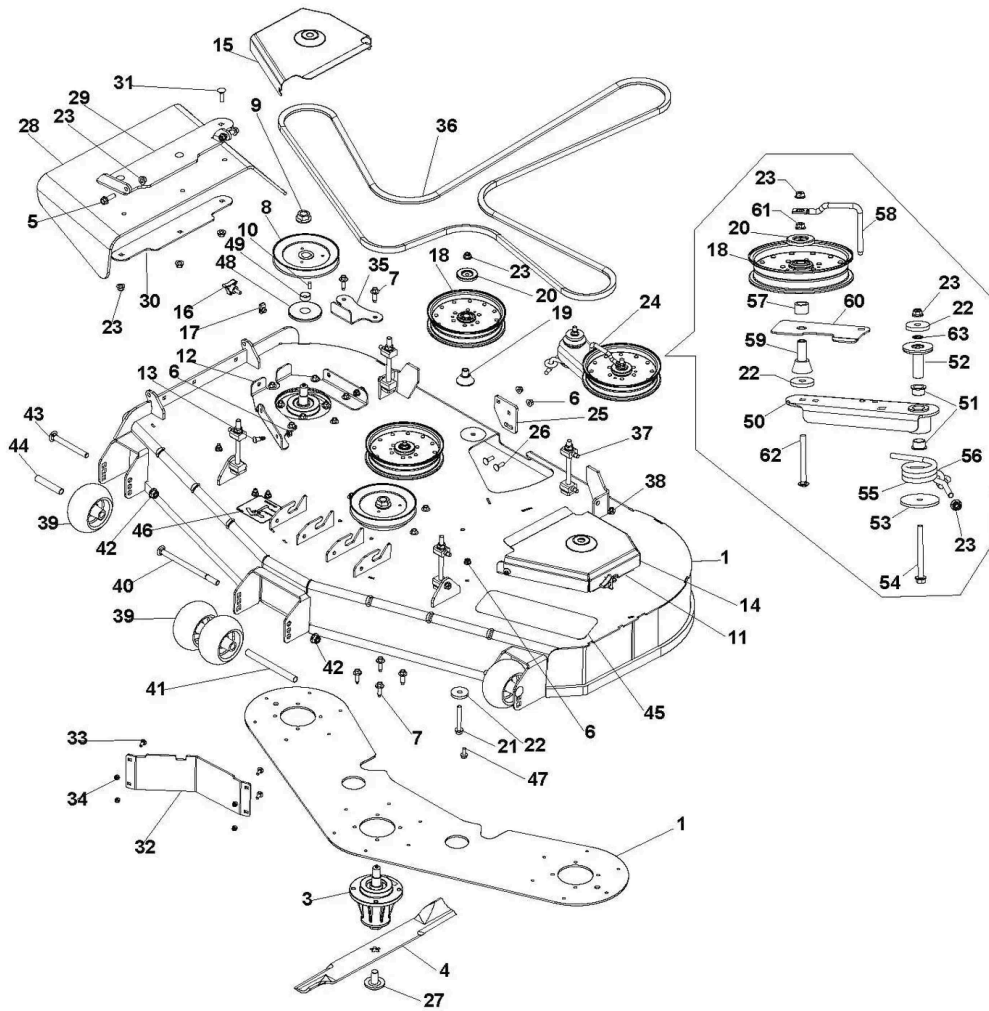

Ref.	Article N.	Description	Qty	Kit
1	598852902	SERVICE KIT	1	-
3	596794501	MANDREL	1	-

<b>Ref.</b>	<b>Article N.</b>	<b>Description</b>	<b>Qty</b>	<b>Kit</b>
4	539105711	BLADE	1	-
5	525834202	SCREW	1	-
6	594944401	NUT	1	-
7	584953901	BOLT	1	-
8	590805101	PULLEY	1	-
9	521996502	NUT	1	-
10	539105308	KEY	1	-
11	597450805	BRACKET	1	-
12	597450806	BRACKET	1	-
13	582476402	SCREW	1	-
14	597452505	COVER	1	-
15	597452506	COVER	1	-
16	597783101	KNOB	1	-
17	539104763	CLIP	1	-
18	597087101	PULLEY	1	-
19	510263701	BEARING	1	-
20	510254502	SHIELD	1	-
21	596436901	SCREW	1	-
22	596770301	WASHER	1	-
23	521996502	NUT	1	-
25	595026402	BRACKET	1	-
26	595901501	BOLT	1	-
27	539119007	SCREW	1	-
28	582468801	CHUTE	1	-
29	582467303	BRACKET	1	-
30	590523702	PLATE	1	-
31	595901101	BOLT	1	-
32	510437502	BAFFLE	1	-
33	596238401	BOLT	4	-
34	595086601	NUT	1	-
35	596506302	BRACKET	1	-
36	588264808	DRIVE BELT	1	-
37	595315901	LINK ASSY	1	-
38	873900600	NUT	1	-
39	574169601	ROLLER	1	-
40	594944501	BOLT	1	-
41	574196502	TUBE	1	-
42	521991102	NUT	1	-
43	510022302	SCREW	1	-
44	574196402	TUBE	1	-
45	539121322	PAD	1	-



<b>Ref.</b>	<b>Article N.</b>	<b>Description</b>	<b>Qty</b>	<b>Kit</b>
46	574437301	DECAL	1	-
47	592858702	BOLT	1	-
48	598440001	CAP	1	-
49	598645501	SPACER	1	-
50	582462702	ARM	1	-
51	539131518	BEARING	1	-
52	582468102	SHAFT	1	-
53	582466402	PLATE	1	-
54	521996602	SCREW	1	-
55	582468002	SPRING	1	-
56	574202002	BOLT	1	-
57	589455202	SPACER	1	-
58	582470202	KEEPER	1	-
59	582468302	SPACER	1	-
60	594913302	BELT GUIDE	1	-
61	873900600	NUT	1	-
62	596584303	SCREW	1	-
63	539913847	BOLT	1	-

# MUFFLER

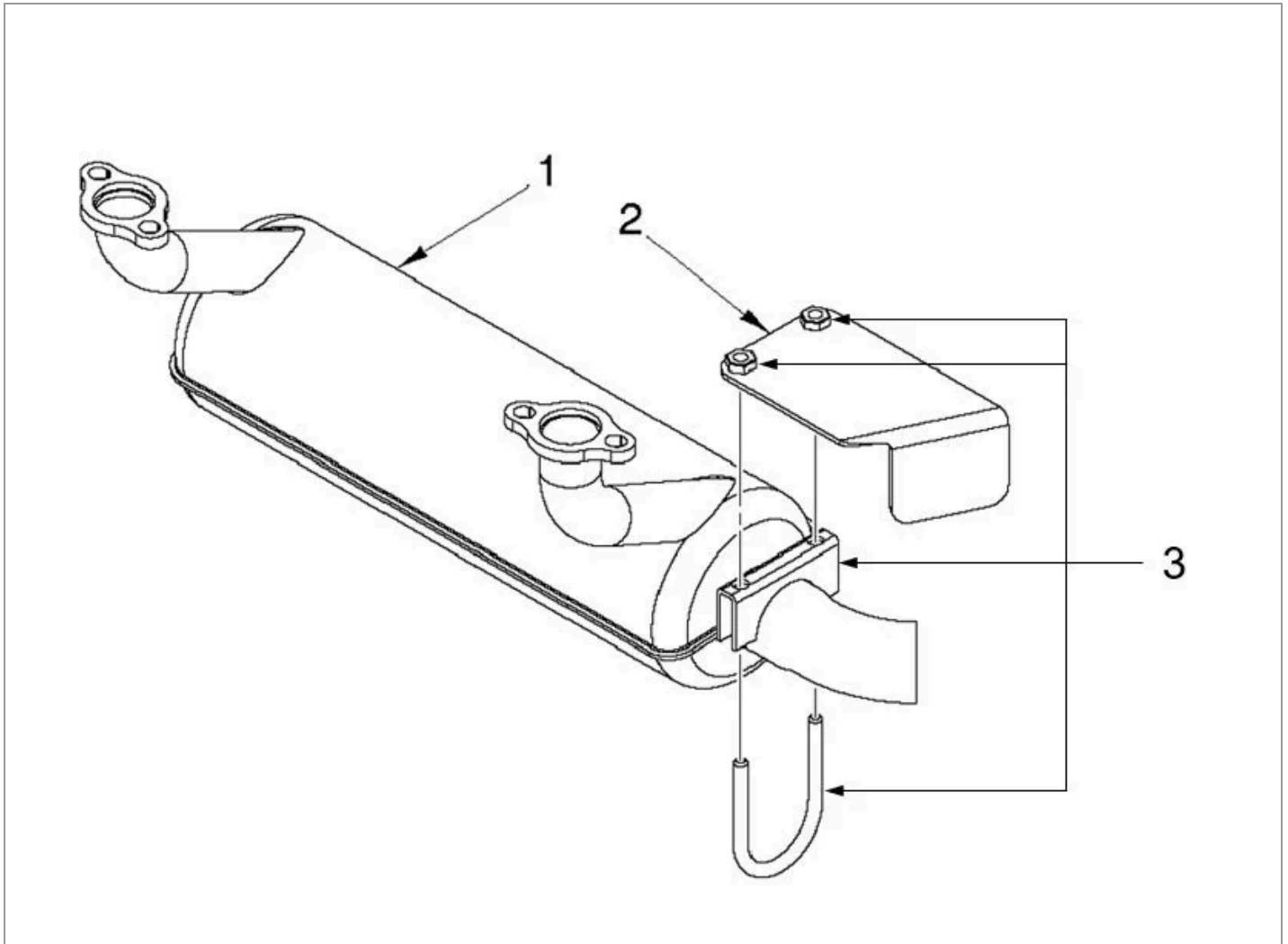

Ref.	Article N.	Description	Qty	Kit
1	525750201	MUFFLER MUFFLER	1	-
2	579150901	SHIELD SHIELD MUFFLER	1	-
3	529359601	SERVICE KIT U-BOLT, CLAMP, & HEX NUTS	1	-

# SEAT

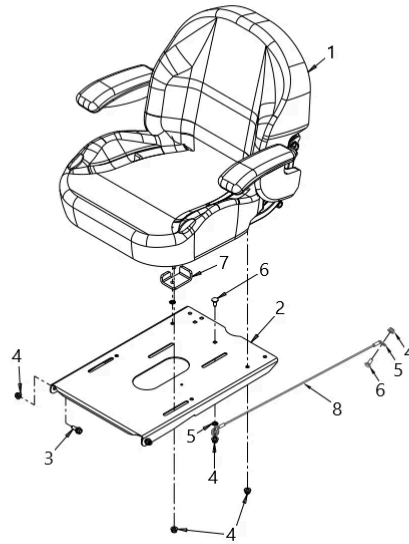

Ref.	Article N.	Description	Qty	Kit
1	597329307	SEAT	1	-
2	595080603	SUPPORT	1	-
3	539130896	BOLT	2	-
4	594944401	NUT	8	-
5	532423063	WASHER	3	-
6	595901601	BOLT	2	-
7	531221602	SEAT STOP BRACKET	1	-
8	532192749	SWITCH NOT SHOWN	1	-
8	595313301	CABLE	1	-
9	579866108	SEAT ASSY ARMREST PAD ONLY	2	-

# SEAT BELT & BRACKET

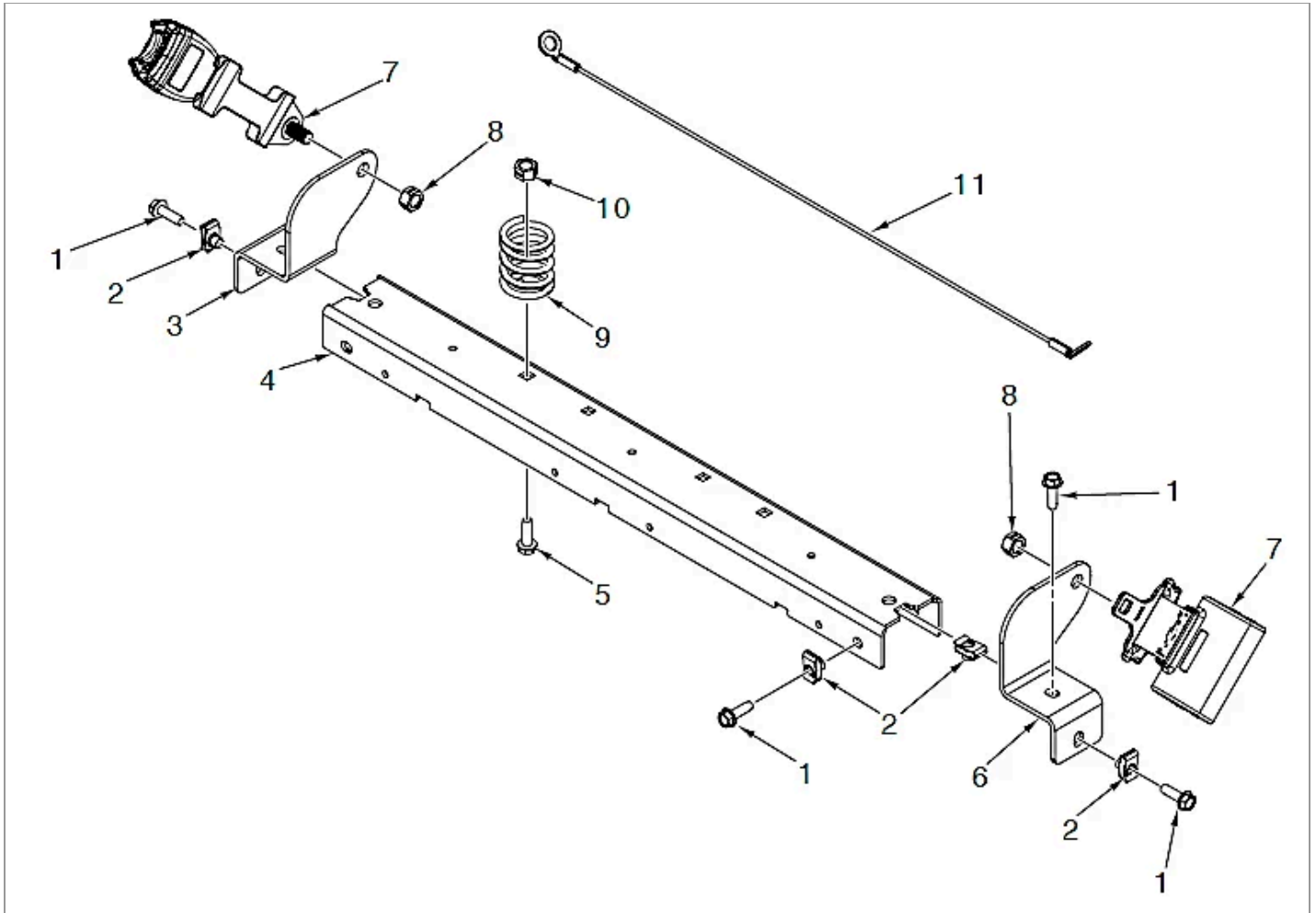

Ref.	Article N.	Description	Qty	Kit
1	596433801	SCREW SCREW HEX HEAD 5/16-18 X 1 IN	1	-
2	539104763	CLIP U-CLIP 5/16-18 NUT RETAINER	6	-
3	595529502	BRACKET BRACKET SEAT BELT RH	1	-
4	595529302	BRACKET BRACKET REAR SEAT	1	-
5	595316801	BOLT BOLT 3/8-16UNC X 1 "	1	-
6	595529402	BRACKET BRACKET SEAT BELT LH	1	-
7	596322702	SEAT SEAT BELT Z400	1	-
8	539990394	NUT LOCKING NUT HEX 7/16F	1	-
9	587613302	SPRING SPRING COMPRESSION	1	-
10	521996502	NUT NUT HEX LOCK 3/8-16 St	4	-

<b>Ref.</b>	<b>Article N.</b>	<b>Description</b>	<b>Qty</b>	<b>Kit</b>
11	595313301	CABLE <i>CABLE LANYARD BLACK</i>	1	-

# STEERING

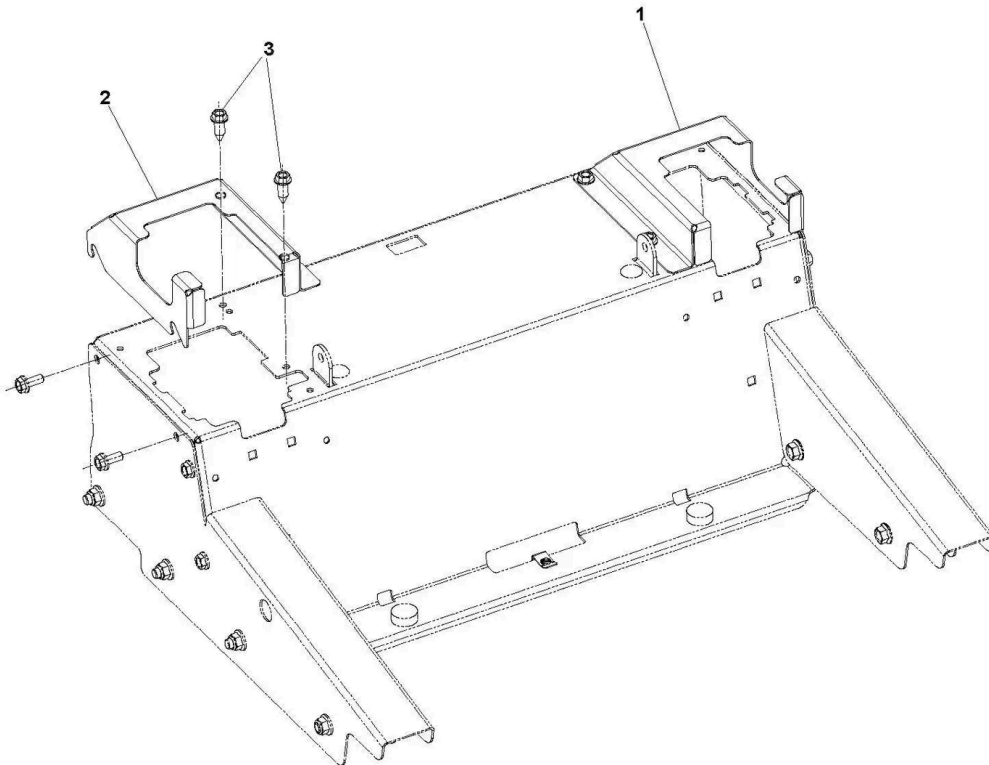

Ref.	Article N.	Description	Qty	Kit
1	599486005	CONTROLS SYSTEM	1	-
2	599486006	CONTROLS SYSTEM	1	-

<b>Ref.</b>	<b>Article N.</b>	<b>Description</b>	<b>Qty</b>	<b>Kit</b>
3	593337601	SCREW	4	-

# STEERING - CONTROL BRACKET

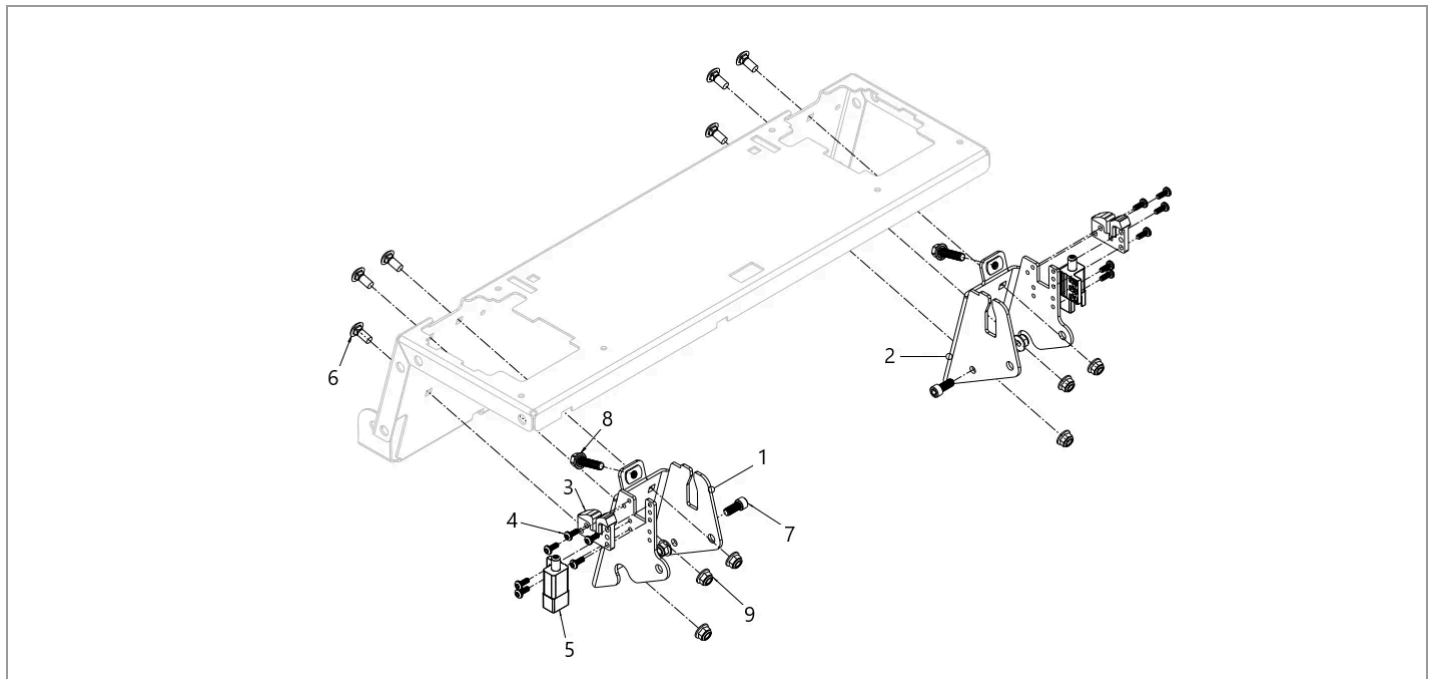

Ref.	Article N.	Description	Qty	Kit
1	596885405	BRACKET <i>LEFT</i>	1	-
2	596885406	BRACKET <i>RIGHT</i>	1	-
3	596290902	GUIDE	2	-
4	597856201	SCREW	12	-
5	587601501	SWITCH	2	-
6	595901601	BOLT	6	-
7	596917101	SCREW	2	-
8	585986101	BOLT	2	-
9	594944401	NUT	8	-



# STEERING - CONTROL MOUNT

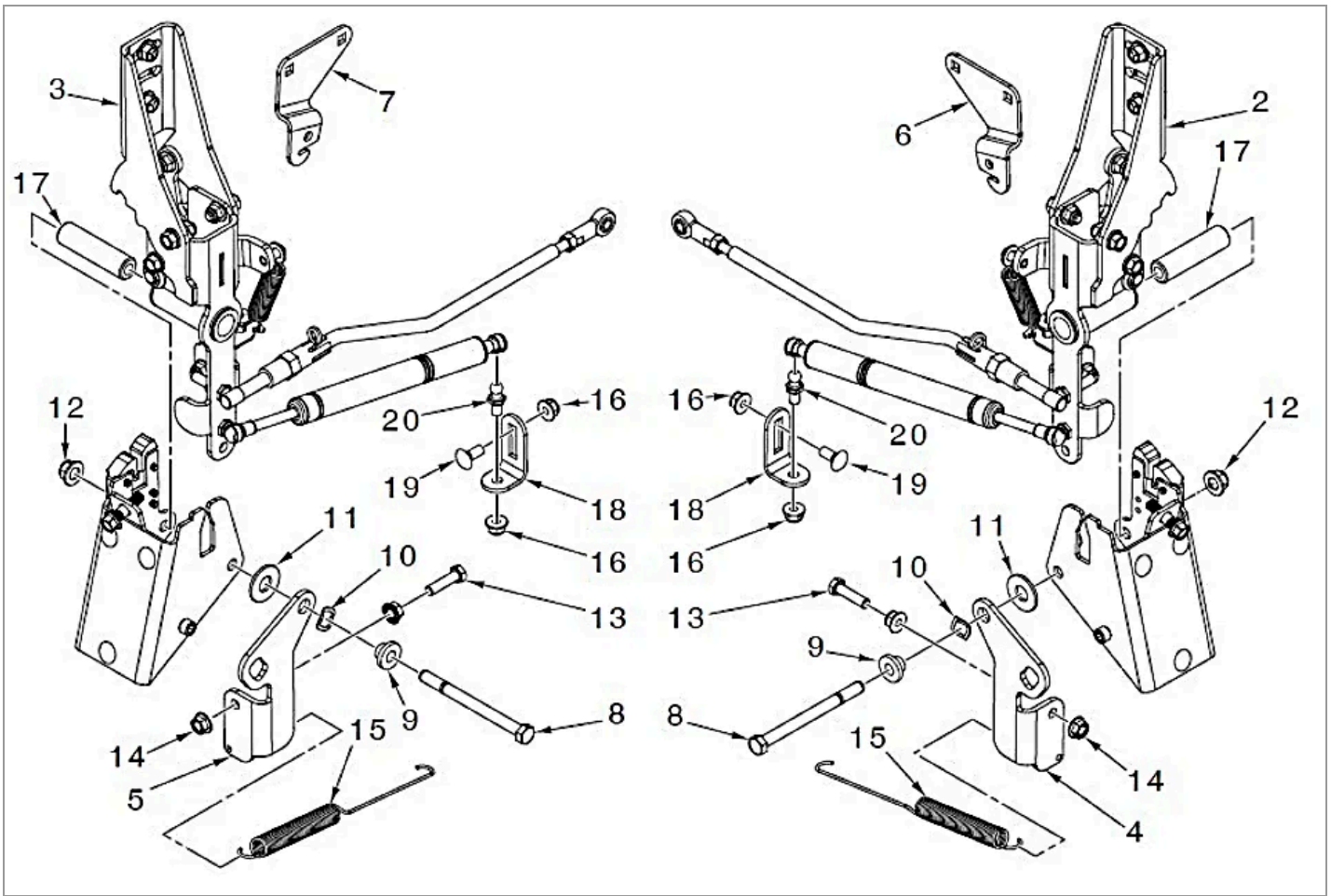

Ref.	Article N.	Description	Qty	Kit
2	598486401	SERVICE KIT CONTROLS SYSTEM LH	1	-
3	598486402	SERVICE KIT CONTROLS SYSTEM RH	1	-
4	596291201	ARM ARM RTN: CONTROLS: MZ LH	1	-
5	596291202	ARM ARM RTN: CONTROLS: MZ RH	1	-
6	593061603	BRACKET BRACKET CONTROLS LH	1	-
7	593061604	BRACKET BRACKET CONTROLS RH	1	-
8	874760672	BOLT BOLT E 3/8-16UNC X 4,5 " Grade 2	2	-
9	596291101	BUSHING BUSHING RTN: CONTROLS: MZ	1	-
10	532444749	WASHER WASHER	2	-
11	585072001	WASHER WASHER	1	-
12	521996502	NUT NUT HEXAGON LOCK 3/8-16	4	-

<b>Ref.</b>	<b>Article N.</b>	<b>Description</b>	<b>Qty</b>	<b>Kit</b>
13	595305701	SCREW <i>SCREW 5/16-18UNC X 31</i>	1	-
14	596039201	LOCK NUT <i>LOCK NUT 5/16-18 IN</i>	1	-
15	593106701	SPRING <i>SPRING CONTROLS</i>	1	-
16	594944401	NUT <i>NUT HEXAGON FLANGE 5/16-18 St</i>	1	-
17	593061501	SPACER <i>SPACER CONTROLS</i>	1	-
18	598475902	BRACKET <i>BRACKET DAMPER</i>	2	-
19	595901601	BOLT <i>BOLT 5/16-18UNC X 0,75 "</i>	1	-
20	594056301	STUD <i>STUD 10MM BALL</i>	1	-

# STEERING - CONTROLS & DAMPER

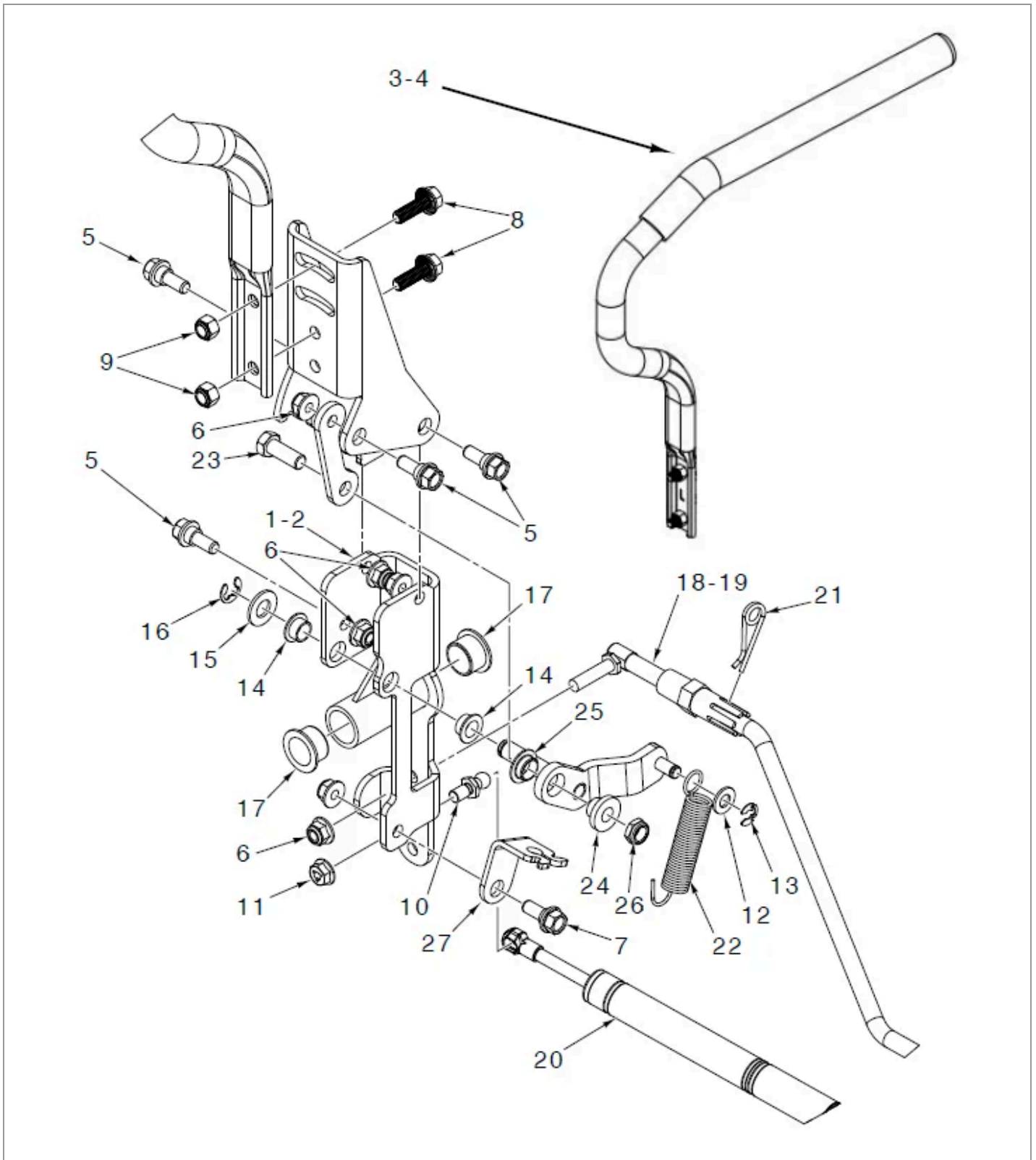

Ref.	Article N.	Description	Qty	Kit
1	598486402	SERVICE KIT CONTROLS SYSTEM RH	1	-

Ref.	Article N.	Description	Qty	Kit
2	598486401	SERVICE KIT CONTROLS SYSTEM LH	1	-
3	596985304	LEVER CONTROL LEVER RH	1	-
4	596985303	LEVER CONTROL LEVER LH	1	-
5	597001301	BOLT BOLT HEX HD 5/16 x 7/8	8	-
6	594944401	NUT NUT 5/16-18	1	-
7	596240701	BOLT BOLT HEX HD 5/16-18 x 5	1	-
8	597001101	BOLT BOLT HEX HD 5/16 x 1	4	-
9	596583702	NUT NUT 5/16-18 x 1	1	-
10	594056301	STUD STUD	1	-
11	596135701	LOCK NUT LOCK NUT 5/16-18	1	-
12	596204101	WASHER WASHER	1	-
13	812000035	CLIP CLIP	1	-
14	501603709	BEARING BEARING FLANGED	4	-
15	597001201	WASHER WASHER	1	-
16	522705201	RING RING 7/16	1	-
17	539131518	BEARING BEARING FLANGED	2	-
18	596862302	ROD CONTROL ROD ASSEMBLY RH	1	-
19	596862301	ROD CONTROL ROD ASSEMBLY LH	1	-
20	588775401	DAMPER DAMPER	1	-
21	582551901	CLIP RETAINING CLIP	1	-
22	597906801	SPRING SPRING	1	-
23	596564401	BOLT BOLT HEX HD 3/8-16 x 1	1	-
24	596291101	BUSHING BUSHING	1	-
25	501603710	BEARING BEARING FLANGED	1	-
26	596230801	NUT NUT	1	-
27	593061302	BRACKET	2	-

# TRANSMISSION

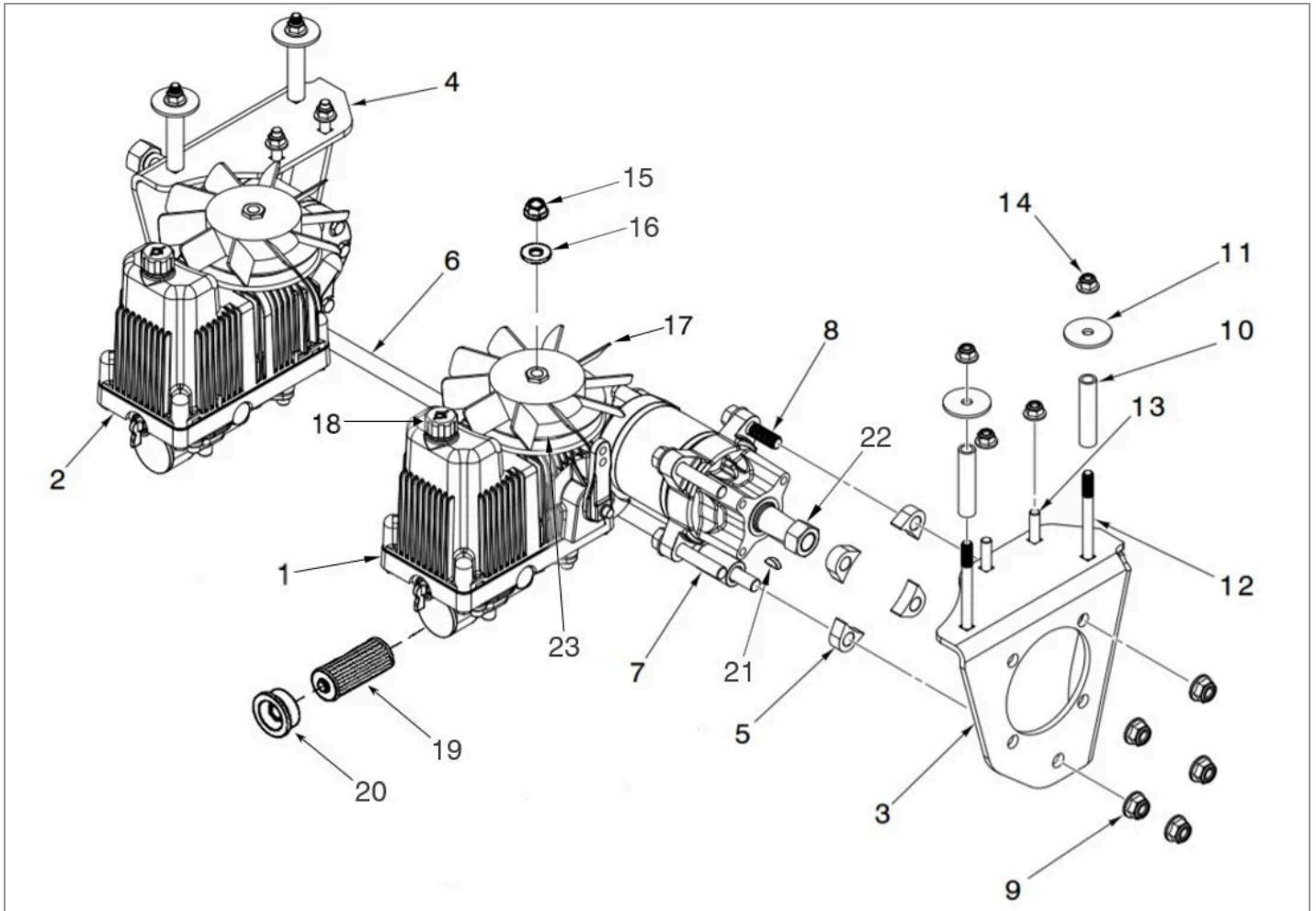

Ref.	Article N.	Description	Qty	Kit
1	594090301	TRANSMISSION 10CC PUMP	1	-
2	594090302	TRANSMISSION 10CC PUMP	1	-
3	596691903	BRACKET BRACKET MTG, XMSN LH, BLK	1	-
4	596691904	BRACKET BRACKET MTG, XMSN RH, BLK	1	-
5	596692501	SPACER	1	-
6	594091101	CROSSBAR SPACER TRANSMISSION	1	-
7	582539502	BOLT	1	-
8	597002001	SCREW	8	-
9	521991102	NUT BOLT FLANGE , 1/2-13 X 2.75 GRD 5	8	-
10	594090801	SPACER SCREW HHFS 1/2-13, 2 IN	4	-
11	596917301	WASHER	1	-

Ref.	Article N.	Description	Qty	Kit
12	525848601	BOLT <i>RHSNB 3/8-16 x 4</i>	4	-
13	596136101	BOLT <i>BOLT 3/8-16UNC X 1,5 " Grade 5 ZPB</i>	4	-
14	521996502	NUT <i>NUT HEX LOCK FLANGE 3/8-16</i>	4	-
15	599371501	RETAINER	2	-
16	599371401	RETAINER	2	-
17	599371301	FAN	2	-
18	596487901	DIPSTICK	2	-
19	599370101	FILTER	2	-
20	599370201	CAP ASSY	2	-
21	599371201	KEY	2	-
22	599370301	AXLE <i>Nut</i>	2	-
23	529358401	PULLEY	2	-
24	536768801	SEAL KIT <i>Not Shown: Top Housing Charge Pump Seals</i>	1	-
25	536769201	PLUG <i>Not Shown: Poppet Valve Plug</i>	1	-
26	536769301	SEAL KIT <i>Not Shown: Seal Kit</i>	1	-
27	536768901	SERVICE KIT <i>Not Shown: 1 Gallon Oil &amp; 2 Filters</i>	1	-

# TRANSMISSION

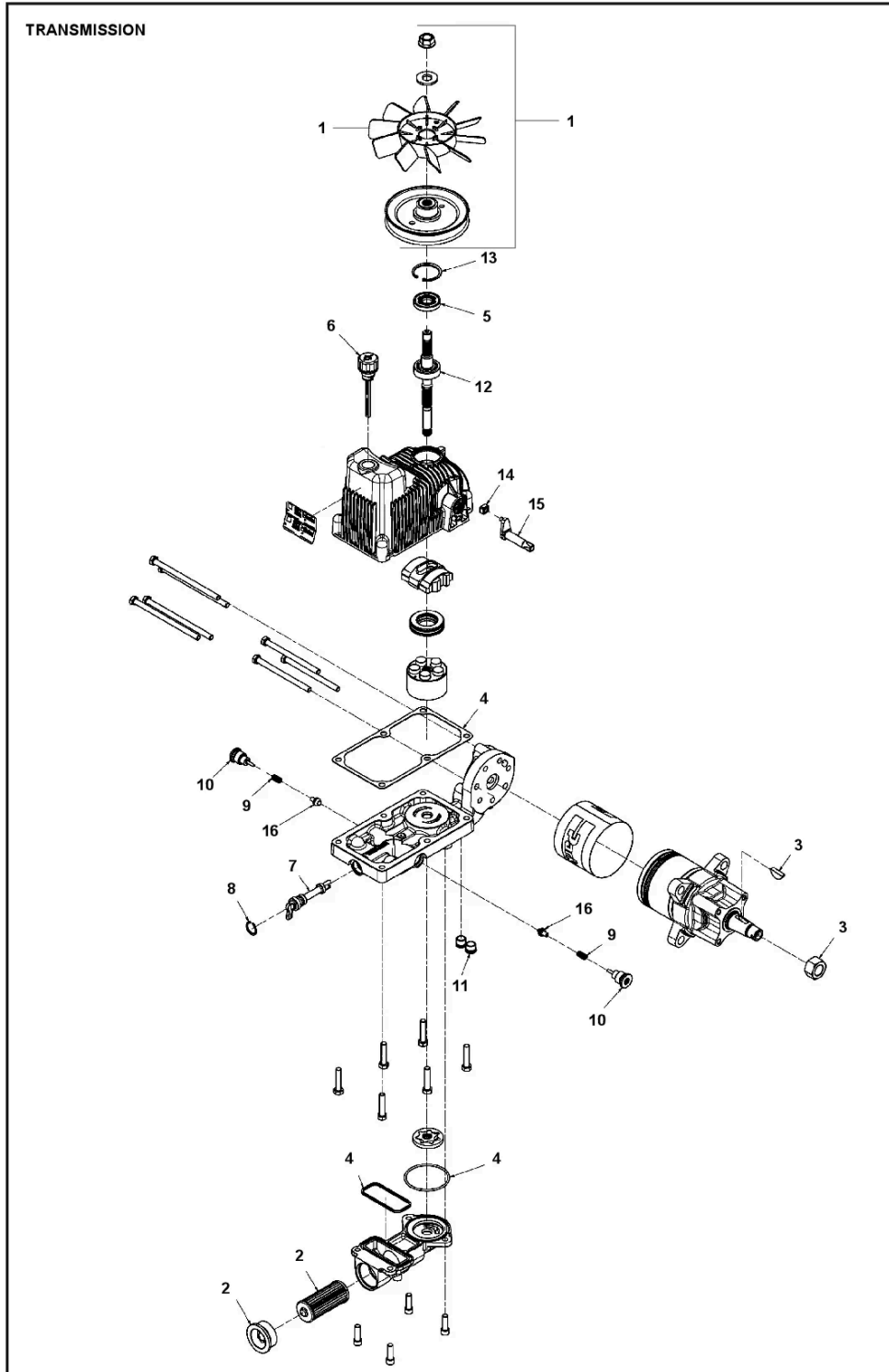

Ref.	Article N.	Description	Qty	Kit
0	594090301	TRANSMISSION <i>Transmission Complete LH</i>	1	-

Ref.	Article N.	Description	Qty	Kit
0	594090302	TRANSMISSION <i>Transmission Complete RH</i>	1	-
1	599371301	FAN <i>Fan ONLY</i>	1	-
1	536769501	FAN SYSTEM <i>Fan / Pulley Kit</i>	1	-
2	599370101	FILTER <i>Filter ONLY</i>	1	-
2	536768901	SERVICE KIT <i>1 GALLON OIL &amp; 2 FILTERS(SERVICES LH &amp; RH)</i>	1	-
2	547960501	SERVICE KIT <i>Filter Kit</i>	1	-
3	547960601	SERVICE KIT <i>Woodruff Key &amp; Nut</i>	1	-
4	536768801	SEAL KIT <i>Seal Kit</i>	1	-
5	546970601	SEAL <i>Shaft Seal</i>	1	-
6	596487901	DIPSTICK <i>Breather / Dipstick</i>	1	-
7	547960701	SERVICE KIT <i>Bypass Vavle</i>	1	-
8	547960801	SERVICE KIT <i>Retaining Ring (Bypass valve)</i>	1	-
9	547961001	SERVICE KIT <i>Spring</i>	1	-
10	547960901	SERVICE KIT <i>Plug &amp; O-Ring</i>	1	-
11	547961101	SERVICE KIT <i>Plug, Magnetic Hex</i>	2	-
12	548018901	SERVICE KIT <i>Shaft Assy</i>	1	-
13	548018801	SERVICE KIT <i>Retaining Ring</i>	1	-
14	548019001	SERVICE KIT <i>Control Block</i>	1	-
15	548019101	SERVICE KIT <i>Trunion Arm</i>	1	-
16	548019201	SERVICE KIT <i>Poppet Valve</i>	2	-



# WHEELS AND TIRES

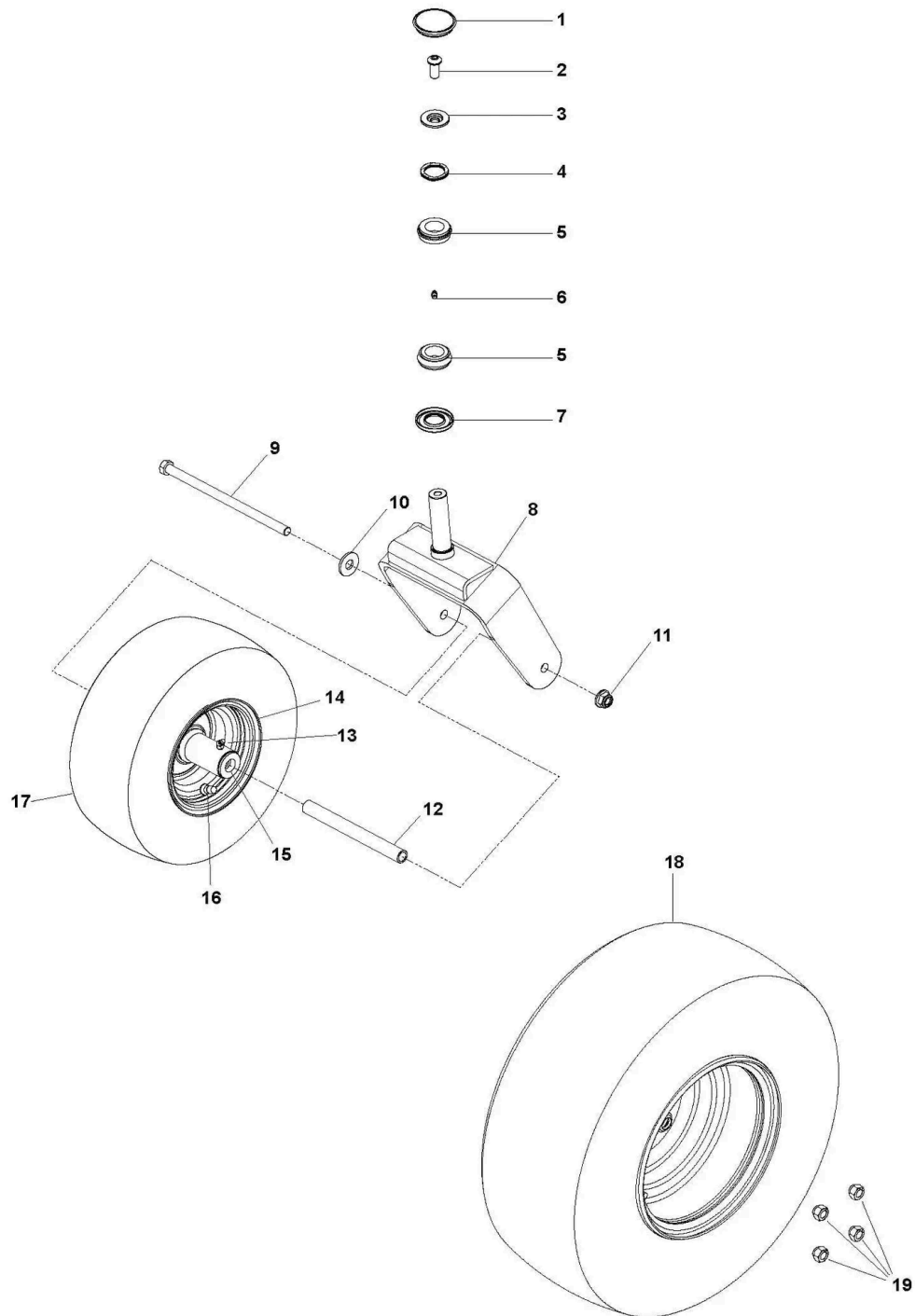

Ref.	Article N.	Description	Qty	Kit
1	590700003	CAP	2	-
2	591457301	SCREW	2	-

<b>Ref.</b>	<b>Article N.</b>	<b>Description</b>	<b>Qty</b>	<b>Kit</b>
3	591425101	CAP	2	-
4	590681601	SPRING	2	-
5	539102543	BEARING	4	-
6	596623501	VALVE	2	-
7	539102851	SEALING	2	-
8	590674607	FORK	2	-
9	539105517	BOLT	2	-
10	819182212	WASHER	2	-
11	521991101	NUT	2	-
12	575334901	SPACER	2	-
13	539103300	NIPPLE	2	-
14	581199503	WHEEL ASSY	1	-
15	539102484	BEARING	2	-
16	539105307	ROLLER BEARING	2	-
17	539105522	TIRE	2	-
18	586955403	WHEEL ASSY	2	-
19	587653903	NUT	8	-